



WAZAN.PK

WEIGHING DELIVERED
WITH PRECISION

Model no.: M02

User's Manual

M02-00150101

110609010002

©2021, Shenzhen General Measure Technology Co., Ltd reserve allcopyright.
Without permission from Shenzhen General Measure Technology Co., Ltd,
Any corporations or person must not copy, spread, record or translate into other
language by any forms.

Our company reserved the right to update user's manual without additional
notice to customers by reason of update, so please visit our website or contact
with our service person to get update information.

Website: <http://www.gmweighing.com>

CONTENTS

1	General Description.....	1
1.1	Functions and Characteristics.....	1
1.2	Front Panel.....	2
1.3	Real Panel.....	4
1.4	Technical Specifications.....	5
1.4.1	Common:.....	5
1.4.2	Analog:.....	5
1.4.3	Digital:.....	6
2	Installation and Wiring.....	7
2.1	Connection of Power Supply.....	7
2.2	Connection of Load Cell.....	7
2.2.1	6 wires connection.....	8
2.3	I/O terminals.....	9
2.4	Optional Expansion Board Output.....	10
2.4.1	Analog Output (Optional).....	10
2.4.2	Serial InterfaceRS485Output.....	13
2.4.3	Serial InterfaceRS232 output (Optional).....	14
3	Calibration.....	15

3.1	Instruction.....	15
3.2	Flow Chart of Calibration.....	16
3.3	Millivolt Value Display.....	21
3.4	Calibration with Weights.....	22
3.5	Calibration without Weights.....	22
3.6	Rough calibration by inputting load cell sensitivity.....	25
3.7	Calibration Switch for Communication Interface.....	26
3.8	Explanation for Calibration Parameters.....	26
4	Working Parameters Setting.....	28
4.1	Flow Chart of Working Parameters Setting.....	28
4.2	Parameter Setting Method.....	30
4.3	Descriptions of Operation Parameters.....	31
4.4	Set point parameters.....	34
4.5	Hold functions parameters.....	35
5	I/O Definition.....	38
5.1	I/O Definition.....	38
5.2	I/O testing.....	40
6	Serial Communication.....	41
6.1	RS- SP1.....	41

6.1.1 Parameters Code Chart.....	41
6.1.2 Error Code Explanation.....	45
6.1.3 Continuous Mode “Cont”.....	45
6.2 r-Cont.....	53
6.3 Modbus protocol.....	54
6.3.1 Modbus communication address.....	56
6.4 YH protocol.....	62
7 Password Input and Setting, Reset.....	64
7.1 Password Input.....	64
7.2 Password Setting.....	64
7.3 Factory Reset.....	66
8 Display Testing.....	68
9 Errors and Alarm Messages.....	69
10 Dimension of Indicator.....	70

1 General Description

M02 weighing indicator is specially designed for weight transmitting in industrial fields.

This indicator has the features of small volume, plenty communicating commands, stable performance, easy operation and practicability. It can be widely applied to concrete and bitumen mixing equipment, metallurgy furnace and converter, chemical industry and feed, etc. . .

1.1 Functions and Characteristics

- Small volume, unique design, easy operation
- Applicable to all kinds of resistance strain gauge bridge load cell
- Front panel numerical calibration
- Multilevel of digital filter
- Automatic zero -tracking
- Automatically zero when powered on
- 4 set points
- 1 input and 2 outputs
- Serial communication interface:RS232 or RS485
- Calibration via serial interface
- Optional interfaces: Analog output, serial interface

1.2 Front Panel

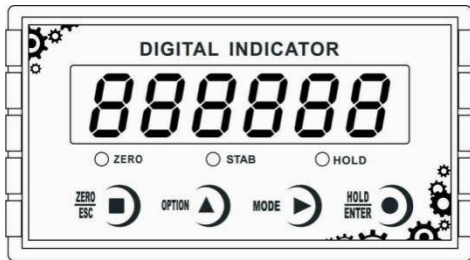

M02 Front panel

Main Display: 6 digits, for displaying weight and the information of parameters.

Status Indicator Lamp:

- **ZERO:** Light on when present weight is within $0 \pm 1/4d$.
- **STAB:** Light on when changes of weight values are within the range of motion detecting during motion detecting time.
- **HOLD:** Light on when indicator displays the value of D/A output.

Keypad:

ZERO
ESC

: Zero/Esc, Used to exit from current operation or go previous.



OPTION

: Selecting key for parameters. Used to scroll optional values of parameter and to make flashing digit increase 1 while data inputting. If flashing digit is 9, press this button to make data increase 1. Long pressing this button to check analog output, short pressing to switch to display last hold value.



MODE

: Function Selecting Key, To make flashing position move to the right digit when data inputting.

HOLD
ENTER

: Confirming Key. Used to confirm present operation.

1.3 Real Panel

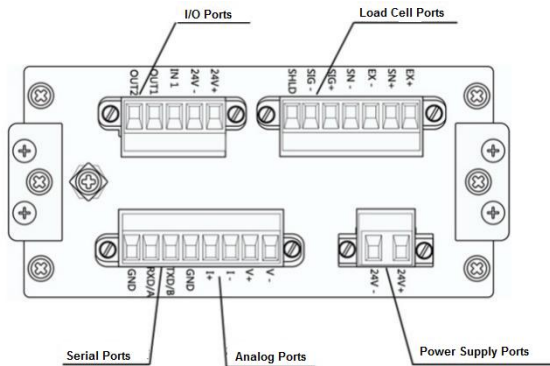

M02 Rear Panel

1.4 Technical Specifications

1.4.1 Common:

Power supply: **DC24V±5%**

Working temperature: **-10~40℃**

Max humidity: **90%R.Hwithout dew**

Power consumption: **About 10W**

Dimension: **110×89×60 (mm)**

1.4.2 Analog:

Load cell power: **DC5V 200mA (MAX)**

Input impedance: **10MΩ**

Zero steady range: **-10~10mV(Load cell 2mV/V)**

Input sensitivity: **0.1uV/d**

Input range: **-15~15mV(Load cell 2mV/V)**

Transfer mode: **Sigma - Delta**

A/D conversion speed: **120times/sec、480times/sec**

Non-linearity: **0.01% F.S**

Gain drift: **10PPM/℃**

Display Precision: **1/100000**

1.4.3Digital:

Weight display: **6digits red high-brightness LED**

Minus display: “-”

Overload display:“**OFL**”

Decimal point: **5 kinds (optional)**

Function keys: **4 keys soniferous keypad**

2 Installation and Wiring

2.1 Connection of Power Supply

M02 weighing indicator connects DC24V power supply as follows:

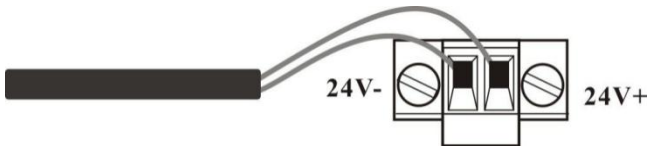

Power supply connection

2.2 Connection of Load Cell

M02 weighing indicator connects bridge type resistance strain gauge load cells by 6 wires or 4 wires as follows. When you use 4-wired load cells, you must bridge the SN+ with EX+ and bridge the SN- with EX-.

The signal definition of each port of the load cell connector is as follows:

EX+: Excitation+ **EX-:** Excitation- **SN+:** Sense+ **SN-:** Sense- **SIG+:** Signal+ **SIG-:** Signal-

6 wires	EX+	SN+	EX-	SN-	SIG+	SIG-	Shield
4 wires	EX+		EX-		SIG+	SIG-	Shield

2.2.16 wires connection

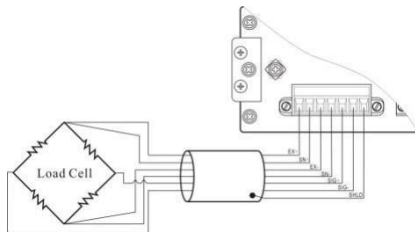

Note:

1. As load cell output sensitive analog signal, please use shield cable to separate with other cables, especially AC power.
2. 4 wires connection is suitable for short distance and stable temperature or low precision field, otherwise use 6 wires connection.
3. For more load cells parallel connection, their sensitivity (mV/V) should be same.

2.3 I/O terminals

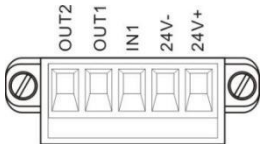

I/O tolerant definition as follows:

Output		Input	
OUT1	Stable	IN1	Zero
OUT2	OFL		

Indicator input terminal connection:

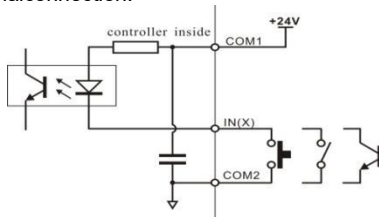

Indicator input terminal connection:

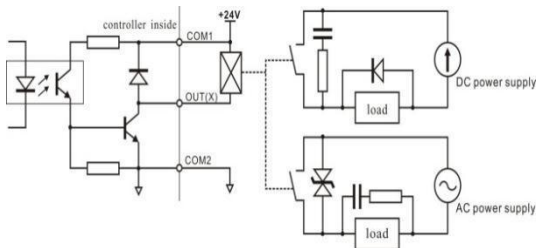

2.4 Optional Expansion Board Output

M02 weighing indicator supports analog output, RS232 or RS485 as optional output function, please confirm it when place orders.

2.4.1 Analog Output (Optional)

At normal displaying status, press



for 3 seconds to switch to display analog output. Format is AXX.XXX.

The definition of analog output as below:

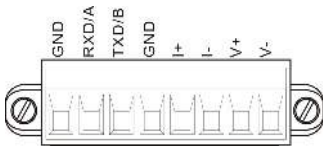

The definition of analog output:

V+: voltage-output+, **V-**: voltage-output-
I+: current-output +, **I-**: current-output -

Analog output two types:

- 1) **Voltage output: 0-5V/0-10V/±5V/±10V is optional .**
- 2) **Electric current output: 4-20mA/0-20mA/0-24mA is optional.**
- 3) **User-define function, users can define analog output type and output range.**

The analog output has been calibrated before the delivery of the indicators, so users do not need to make calibration. If analog output is abnormal, users can calibrate by themselves as follows: (Suggestion: please calibrate under the instruction of professionals)

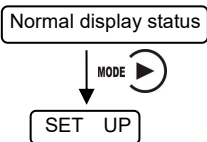

Note: only support calibration under current mode.4 points must be finished for current calibration.

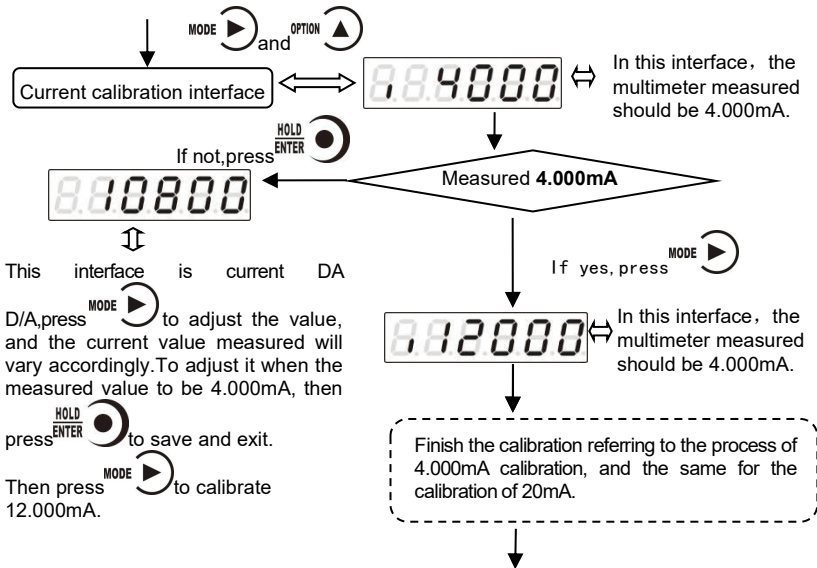

This interface is current DA

D/A, press MODE to adjust the value, and the current value measured will vary accordingly. To adjust it when the measured value to be 4.000mA, then

press HOLD ENTER to save and exit.

Then press MODE to calibrate 12.000mA.



This interface is the highest point calibration of analog output.

In the interface of highest point calibration, press  to enter into analog display value interface, the display will be 5 digits (initial value is **24000**, means

24.000mA), press  to input the value measured by the multimeter.

Note: Analog output calibration, highest point must be calibrated.

2.4.2 Serial Interface RS485 Output

Serial Interface RS485 output is optional, please refer to chapter 6.0 for communication protocol.

RS485 serial interface connection:

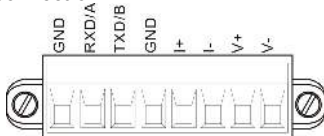

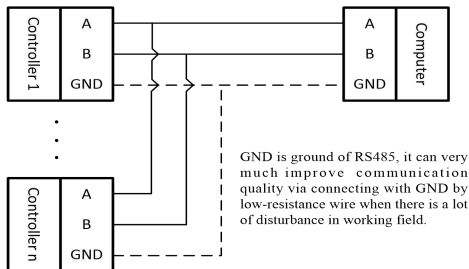

2.4.3 Serial Interface RS232 output (Optional)

RS232 serial interface connection:

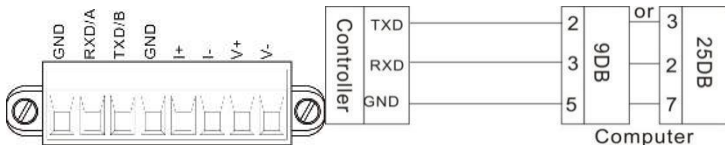

3 Calibration

3.1 Instruction

(1) Calibration procedure must be executed when a M02 indicator is put in use at the first time, the preset parameters may no longer meet the user's needs, and any part of the weighing system was changed. Position of decimal point, minimum division, maximum capacity, zero, and gain can be set and confirmed through calibration.

(2) If you want to set only one parameter, please press  to save parameter's

value and then press  to exit.



(3) Please see section 3.7 for parameters' instruction.

(4) Please record each value in the blank table in section 3.4 during calibration for the emergency use in future.

(5) See chapter 9 for error alarm message that may be displayed during calibration.

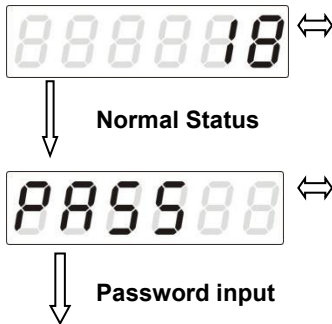
3.2 Flow Chart of Calibration



1. Under this status, press  (twice), indicator will display **CAL**, then press  to enter password input.
2. After password is input, the indicator will display **CALON** for one second, then go to next step.



Decimal point





Min. division





Max. capacity



3. Press  to select a desired value for decimal point among 0, 0.0, 0.00, 0.000 and 0.0000, and then

press  to save it and enter next step. If there's no need to change the value,

press  directly to enter next step.

4. Press  to select a desired value for min. division among 1,2, 5,10,20 and 50, and then to save it and enter next step.

If there's no need to change the value, then press  directly to enter next step.

5. Input max. capacity(\leq min. division \times 100000),

press  to save it and enter next step. If there's no need to change the value, then

press  directly to enter next step.



6. Under this status, press  to enter zero calibration.

Display value near the output value in millivolt between **SIG+ / SIG-** of load cell.

See section [3.3](#) for details about this function.



Millivolt value display



7. Unloaded scale first, when **STAB** lamp is on,

press  to finish zero calibration.

If there's no need to calibrate zero,

press  directly to enter gain calibration.

Zero calibration

8. The process of gain calibration is as follows. If there's no need to do gain calibration, press



directly to enter serial ports calibration switch setting.

Gain Calibration

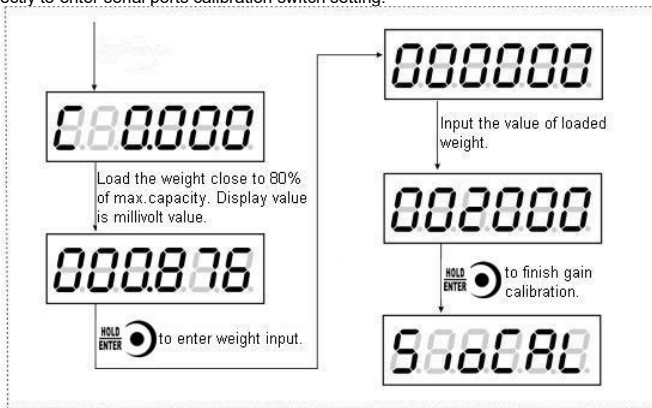

Serial ports
 calibration switch

Password setting



Normal status



9. Press to enter setting

interface, press to choose the switch position,

press to set password. If don't need to set

switch position, then press to enter password setting.

10. See section 7.2 for reference to set password. If there's no need to set password,

press directly to go back to normal status.

3.3 Millivolt Value Display

This function is mainly used for system test, position-error test for weighing mechanism and linearity test for load cell.

1. System Test

(1) If display data changes with loaded weight changes, it shows that connection of load cell is correct and weighing mechanism works well.

(2) If display value is OFL (or -OFL), it means that loaded weight on load cells is too large (or too small). Please unload the weight (or load more), if display value is still OFL (or -OFL), the possible reasons are as follows:

- There is something wrong with weighing mechanism, please check and clear.
- The connection of load cell is incorrect, please check and clear.
- Load cells may be damaged, please replace.

2. Position-error Test for Weighing Mechanism

Load a same weight on each corner of weighing mechanism and record displayed millivolt value respectively. If differences among these values are obvious, please adjust weighing mechanism.

3. Linearity Test for Load Cell

Load same weight for several times, and record displayed value every time. If one or two values are obviously much larger or smaller than any others, it means that the linearity of load cell is bad.

***NOTE: You must use**



to zero display data before weight is loaded for each time.

3.4 Calibration with Weights

During calibration with weight, please record the zero millivolt value, gain millivolt value and the loaded weight value in the blank table below. If it is not convenient to load a weight to calibrate, these values can be used for calibration without weights.

	Zero millivolt value(mV)	Gain millivolt value(mV)	Loaded Weight	Date	Remarks
1					
2					
3					
4					
5					

3.5 Calibration without Weights

When it is not convenient to load a weight to calibrate, alibration can be done without weights using recorded data in the table in section 3.4.

However, this method is just used for some emergencies, it will make calibration result incorrect if load cells, or indicator has been replaced.

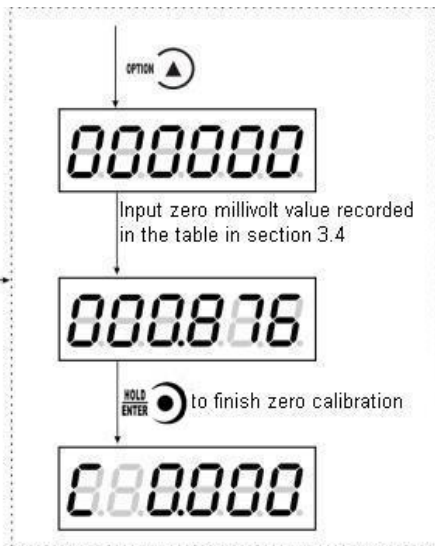

Gain Calibration

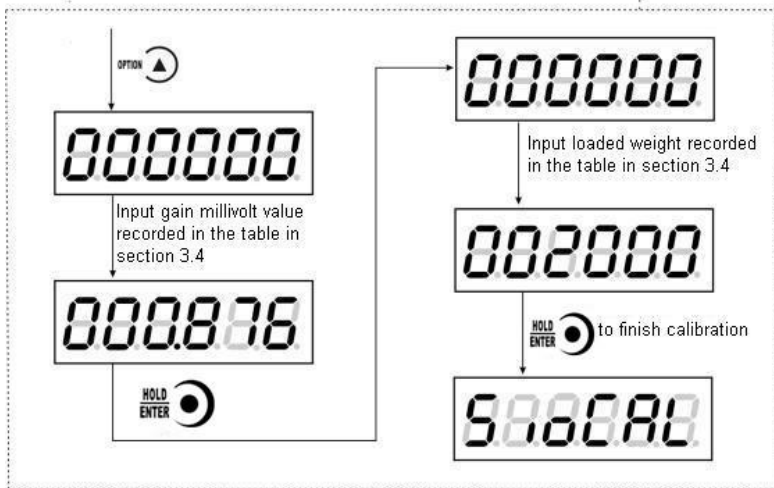

3.6 Rough calibration by inputting load cell sensitivity

Steps as follows:

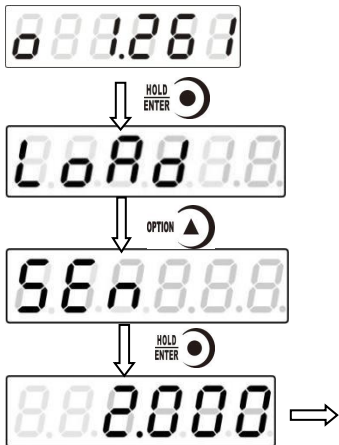

Use **MODE** and **OPTION** to input load cell sensitivity, rough calibration will be completed after confirmed.

Note: This sensitivity value is constrained by the maximum capacity.

3.7 Calibration Switch for Communication Interface

When calibrate the transmitter through serial port(Rs, SP1 or Modbus), must set to “ON” status for the calibration switch for communication interface.

3.8 Explanation for Calibration Parameters

Symbol	Parameter	Types	Value of parameter	Default
Pt	Decimal Point	5	0 0.0 0.00 0.000 0.0000	0
1d	Min. Division	6	1 2 5 10 20 50	1
CP	Max. Capacity		$\leq \text{Min. Division} \times 100000$	10000
t	Millivolt Value			
o	Zero			
C	Gain			
SIOCAL	Switch for Calibration via serial interface			OFF
PASS	Password Setting			000000

Log Table for Calibration Parameters

Parameter	Calibrated Value	Date	Remarks
Decimal Point			
Min. Division			
Max. Capacity			
Load cell sensitivity			
Password			

4 Working Parameters Setting

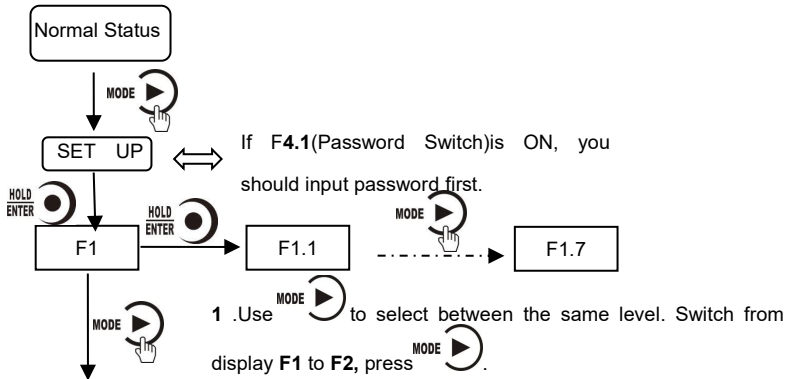

4.1 Flow Chart of Working Parameters Setting

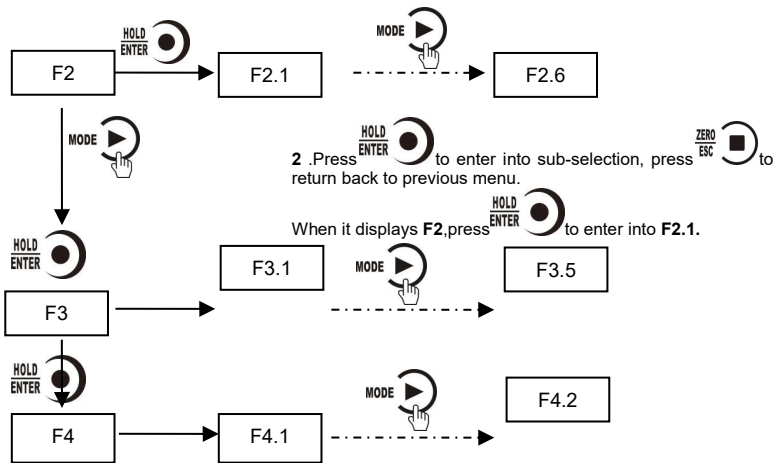



4.2 Parameter Setting Method

M02 has 2 kinds of working parameters: Selection type and Data type. For

selection type parameters, press  to choose. For data type parameter in parameter interface, press  to choose digit position, press  select value.

Selection:



Data:

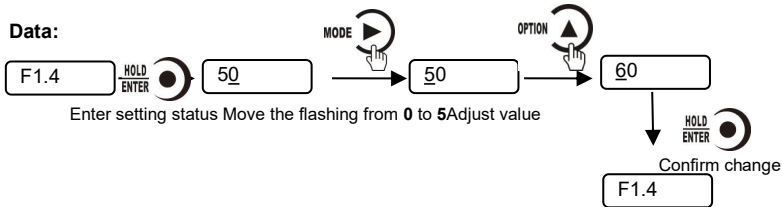

4.3 Descriptions of Operation Parameters

Code	Para.	Default	Description
F1	Null	Null	The first major term of working parameter.
F1.1	ON/OFF	OFF	Switch for Auto-Zeroing when power-on, OFF: disabled ON: enabled
F1.2	0-9	0	Zero-tracking Range (0~9d optional) . This parameter is for automatic calibration, disabled when is set "0".
F1.3	1-9	1	Motion Detecting Range (1~9d optional)
F1.4	00-99	50	Zeroing Range (00%~99% of Maximum capacity)
F1.5	0-9	5	Digital filtering parameter: 0: without filtering 9: strongest digital filtering
F1.6	0-9	0	Stable filter parameter (the second filter based on the first filter) : 0: without filtering 9: strongest digital filtering
F1.7	0~1	0	times/second for A/D conversion rate.120/480

F2	Null	Null	The second major term of working parameter.
F2.1	00~99	01	Scale no., indicator no.
F2.2	9600~57600	9600	Baud rate of serial port 1200, 9600, 19200, 38400, 57600 optional
F2.3	b-rtu/ b-ASC/ Cont/ rS-SP1/	b-rtu	Serial ports communication mode: Modbus-RTU: MODBUSRTU mode; Cont: continuous; rS-SP1: details pls refer to sectio 6.1 yH: yH continue mode
F2.4	7-E-1/ 7-O-1/ 8-E-1/ 8-O-1/ 8-n-1/ 8-n-2	8-E-1	Data format: 7-E-1: 7data bits, even parity check, 1stop bit; 7-O-1: 7data bits, odd parity check, 1stop bit; 8-E-1: 8data bits, even parity check, 1stop bit; 8-O-1: 8data bits, odd parity check, 1stop bit; 8-n-1: 8data bits, noparity check, 1stop bit; 8-n-2: 8data bits, noparity check, 2stop bit;
F2.5	HiLo LoHi	HiLo	MODBUS dual-byte register storage turn , Hi Lo : High byte in the front, low byte at the back; Lo Hi: Low byte in the front, high byte at the back

F2.6	none/10/2 0/30/40/ 50	nonE	Cont mode automatic sending time interval
F3	Null	Null	The third major term of working parameter. (For analog output only)
F3.1	4-20/ 0-20/ 0-24/ 0-5/ 0-10/ I_out/ V_out	4-20	Analog output: 4-20: 4-20mA 0-20: 0-20mA 0-24: 0-24mA 0-5: 0-5V 0-10: 0-10V ±5: ±5V ±10: ±10V I_out: Current customized V_out: Voltage customized Only in customized mode, F3.2-F3.5 parameters are available
F3.2	-24000~ 24000	3920	Minimum output
F3.3	-24000~ 24000	4000	Zero point output

F3.4	-24000~ 24000	20000	Maximum capacity output
F3.5	-24000~ 24000	20020	Maximum output
F4	Null	Null	The fourth major term of working parameter.
F4.1	ON/OFF	OFF	Parameters password setting switch.
F4.2	*****	000000	Parameters password setting: Valid when F4.1 is ON

4.4 Set point parameters

Code	Para.	Default	Description
P1-P4	Null	Null	The first term of working parameters
PX.1	ON/OFF	OFF	Change of state if need stable
PX.2	0.0~99.9	0.0	Change of state minimum duration
PX.3	0	0	Condition of validity: 0: forbid; 1: <; 2: <= 3: ==;

			4: >=; 5: >; 6: !=; compare to minimum value 7: _<>_outside the range, need to set 2 edge value 8: =<_>=inside the range, need to set 2 edge value 9: external trigger. If it's IO, do 1 state change for 1 trigger, if it's command, then decide according to valid or invalid command.
PX.4	-99999~ 99999	0	Set value 1 (Set value 1 and set value 2, choose the minimum to compare)
PX.5	-99999~ 99999	0	Set value 2

Set point has 4major terms which are user defined.

4.5 Hold functions parameters

Code	Para.	Default	Description
------	-------	---------	-------------

HOLD	Null	Null	The first term of working parameters
H1	0~4	0	Hold mode: 0: No hold function; 1: Peak hold; 2: valley hold; 3: Peak-valley hold; 4: sampling value hold
H2	0~1	0	Hold triggering condition: 0: External Trigger (valid when triggered by on-off input or external command) 1: Zero trigger (only valid for peak hold and valley hold)

H3	0~999999	100	<p>Zero value(Valid when H2 is zero trigger. At peak hold mode, hold function starts when display value is over zero value. At valley hold mode, hold function starts when display value is under negative zero value. Hold ends after display value come back to zero value.Indicator will save the value till the next hold starts.</p> <p>Users can switch display status by pressing  in the process.)</p>
-----------	-----------------	------------	--

5 I/O Definition

5.1 I/O Definition

Output/Input code table:

Output		
Code	Definition	Description
O0	None	No definition
O1	Stable	Effective output in stable status.
O2	Overflow	Effective output when overflow.
O3	Sp1	Effective output when set point 1 status output.
O4	Sp2	Effective output when set point 2 status output.
O5	Sp3	Effective output when set point 3 status output.
O6	Sp4	Effective output when set point 4 status output.

Input		
Code	Definition	Description
I0	None	No definition
I1	Zeroing	Effective input for zeroing, pulse input signals
I2	Sp1	If this signal is valid, Sp1status will be regarded as invalid. Output valid state when comparison condition turns to invalid, and be effective again.
I3	Sp2	If this signal is valid, Sp2 status will be regarded as invalid. Output valid state when comparison condition turns to invalid, and be effective again.
I4	Sp3	If this signal is valid, Sp3 status will be regarded as invalid. Output valid state when comparison condition turns to invalid, and be effective again.
I5	Sp4	If this signal is valid, Sp4status will be regarded as invalid. Output valid state when comparison condition turns to invalid, and be effective again.



16	Trigger hold	When hold mode is external trigger, this input is valid for 1 time and start hold status. Stop hold status with another valid signal.
17	Electrical level hold	When hold mode is external trigger, this signal is valid. If it's trigger hold, this signal is invalid and hold off.

5.2 I/O testing

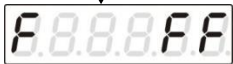

Normal Status



Under weighing status, press  (5 times), then display **TESTio**, press  enter into I/O testing interface.

Press  **OUT1** status flash,

press  **OUT2** status flash.

This interface shows: **IN1** input valid, **OUT1** output valid.

6 Serial Communication

M02 has RS232 or RS485 as optional to realize communication with upper computer. Communication protocols support:RS-SP1and Modbusprotocol(bus).

6.1 RS- SP1

2 working modes::continuous mode(**Cont**)/command mode(**Read**).

Data format:Select and set in communication parameters

Baud Rate: **9600/19200/38400/57600** (optional)

Code : **ASCII**

Operation code supported: **W, write; R, read; C, calicate; O, zero**

6.1.1 Parameters Code Chart

Operation code	Para. code	Para. Name	number of character
R	WT	Read current status and weight	8
R	SP	Read set point status	4
W	DC	Write mini. Divistion and max. capacity	8
R/W	PT	Decimal point digit	1

R	DD	Minimum division	2
R	CP	Maximum capacity	6
R/W	AC	Auto. Zeroing switch	1
R/W	TR	Zero tracking range	1
R/W	MR	Stable range	1
R/W	ZR	Zeroing range	2
R/W	FL	digital filtering para.	1
R/W	VC	steady filtering	1
R/W	AD	AD sample rate	1
R	PO	Set point output status	4
R/W	P1M~P4M	Set point to judge if need stability	1
R/W	P1T~P4T	Set point minimum duration time	3
R/W	P1F~P4F	Set point comparison condition to judge	1
R/W	P1L~P4L	Set point lower edge value to judge	6
R/W	P1H~P4H	Set point upper	6

		edge value to judge	
R/W	HM	Hold mode	1
R/W	HF	Trigger condition	1
R/W	NZ	Zero value	6
R	HW	Hold value	6
R	HS	Trigger hold status	1(0: Trigger invalid, 1: Trigger valid)
R	AM	Absolute millivolt	7: D6D5D4D3D2D1D0; D6:+;D5-D0: corresponding ASCII for 6 digits millivolt,Decimal point is fixed to 3 digits
R	RM	Relative zero point on millivolt	7: D6D5D4D3D2D1D0 D6: +/-;D5-D0:corresponding ASCII for 6 digits , Decimal point is fixed to 3 digits
C	ZY	Zero calibration with weight	
C	ZN	Zero calibration without weight	6
C	GY	Gain calibration with weight	6
C	GN	Gain calibration without weight	12

C	G1	Gain1 calibration with weight	6
C	G2	Gain2 calibration with weight	6
C	G3	Gain3 calibration with weight	6
C	G4	Gain4 calibration with weight	6
O	CZ	Zero clearing command	
O	P1S~ P4S	Setting the corresponding set point	Valid when 9,command valid when external trigger and 1 status change for 1 external Trigger
O	P1C~P4 C	Clear the corresponding set point	
O	HS	Setting trigger condition	

Take an example:

02 30 31 31 31 43 47 31 30 30 30 32 30 30 32 35 0D 0A (Gain1 calibration with weight)

Present weight is 200.

Correct format: 02 30 31 31 43 47 31 4F 4B 31 34 0D 0A

Wrong format: 02 30 31 35 43 47 31 45 36 36 32 0D 0A

6.1.2 Error Code Explanation

- 1: CRC check error
- 2: Operation code error
- 3: Parameters code error
- 4: Write data error
- 5: Operation invalid
- 6: Channel no. error

Note: Default channel no. of this indicator : **1 (31H)**

6.1.3 Continuous Mode “Cont”

Indicator will send weighing data to host computer without command.

6.1.3.1 Host computer read present status

Data Format:

STX	Scale no.	Channel no.	Status	Value	CRC	CR	LF
------------	------------------	--------------------	---------------	--------------	------------	-----------	-----------

Correct response:

STX	Scale no.	Channel no.	R	WT	Status	Value	CRC	CR	LF
------------	------------------	--------------------	----------	-----------	---------------	--------------	------------	-----------	-----------

Wrong response:

STX	Scale no.	Channel no.	R	WT	E	Error code	CRC	CR	LF
------------	------------------	--------------------	----------	-----------	----------	-------------------	------------	-----------	-----------

Here:

STX — 1bit, start character **02H**

R — 1 bit, **52H**

WT — 2 bit, **57H 54H**

E — 1 bit, **45H**

Status — 2bits, high byte:**40H**; low byte definition as follows:

D6	D5	D4	D3	D2	D1	D0
Null	Null	G./N. weight	+/-	Zero point	OFL	Stable
1	0	0	0: + 1: -	0: non/zero 1: zero	0: normal 1: OFL	0: not stable 1: stable

Weight Value — 6bits ; when weight is+ (-) overflow,return to“spacespace**OFL**space”

CRC — 2bits,check sum

CR — 1bit, **0DH**

LF — 1bit, **0AH**

For example:

02 30 31 31 40 4120 20 20 37 30 30 32 34 0D 0A

Means: stable,positive data,present weight **700**

Correct response : **02 30 31 31 52 57 54 40 41 30 30 33 37 35 33 33 36 0D 0A**
 (**stable**present value **3753**)

Wrong response: **02 30 31 31 52 57 54 45 31 31 39 0D 0A** (CRC check error)

6.1.3.2 Read other parameters

Send command:

STX	Scale no.	Channel No.	R	Para. code	CRC	CR	LF
------------	-----------	-------------	----------	-------------------	------------	-----------	-----------

Correct response:

STX	Scale no.	Channel No.	R	Para. code	Value	CRC	CR	LF
------------	-----------	-------------	----------	-------------------	-------	------------	-----------	-----------

Wrong response:

STX	Scale no.	Channel No.	R	Para. code	E	Error code	CRC	CR	LF
------------	-----------	-------------	----------	-------------------	----------	------------	------------	-----------	-----------

Here:

Para. Value—— 1byte

Para. code——2 bytes,

For example:

02 30 31 31 524D52 3839 0D 0A

Correct response: **02 30 31 31 52 4D 52 36 34 33 0D 0A** (stable range: 6)

Wrong response:**02 30 31 31 53 4D 52 45 32 30 39 0D 0A** (Operation code error)

6.1.3.3 Write max. Capacity and min. Division

Send command:

STX	Scale no.	Channel No.	W	DC	Division value	Max. capacity	CRC	CR	LF
------------	-----------	-------------	----------	-----------	----------------	---------------	------------	-----------	-----------

Correct response:

STX	Scale no.	Channel No.	W	DC	O	K	CRC	CR	LF
------------	-----------	-------------	----------	-----------	----------	----------	------------	-----------	-----------

Wrong response:

STX	Scale no.	Channel No.	W	DC	E	Error code	CRC	CR	LF
------------	-----------	-------------	----------	-----------	----------	------------	------------	-----------	-----------

Here:

DC—2 bytes, **44H 43H**

O—1 byte, **4FH**

K—1 byte, **4BH**

Division value—2 bytes, **1/2/5/10/20/50**

Max. capacity—6 bytes

For example:

02 30 31 3157 44 43 30 35 30 31 30 30 30 30 36 30 0D 0A(division value 5, Max capacity 10000)

Correct response: **02 30 31 31 57 44 43 4F 4B 32 34 0D 0A**

Wrong response: **02 30 31 31 57 44 43 45 35 39 32 0D 0A** (Operation can't execute)

6.1.3.4 Write other parameters

Send command:

STX	Scale no.	Channel No.	W	Para. code	Para. value	CRC	CR	LF
------------	-----------	-------------	----------	-------------------	-------------	------------	-----------	-----------

Correct response:

STX	Scale no.	Channel No.	W	Para. code	O	K	CRC	CR	LF
------------	-----------	-------------	----------	-------------------	----------	----------	------------	-----------	-----------

Wrong response:

STX	Scale no.	Channel No.	W	Para. code	E	Error code	CRC	CR	LF
------------	-----------	-------------	----------	-------------------	----------	------------	------------	-----------	-----------

For example:

02 30 31 31 57 5A 52 35 30 30 38 0D 0A (Write zeroing range to 50)

Correct response: **02 30 31 31 57 5A 52 4F 4B 36 31 0D 0A**

Wrong response: **02 30 31 31 57 5A 53 45 33 32 38 0D 0A** (Para. Code error)

6.1.3.5 Calibration Zero

1) Calibrate zero as per current weight (with weight)

Send command:

STX	Scale no.	Channel No.	C	ZY	CRC	CR	LF
------------	-----------	-------------	----------	-----------	------------	-----------	-----------

Correct response:

STX	Scale no.	Channel No.	C	ZY	O	K	CRC	CR	LF
------------	-----------	-------------	----------	-----------	----------	----------	------------	-----------	-----------

Wrong response:

STX	Scale no.	Channel No.	C	ZY	E	Error code	CRC	CR	LF
------------	-----------	-------------	----------	-----------	----------	------------	------------	-----------	-----------

Here:

Z——1 byte, **5AH**

Y——1 byte, **59H**

For example:

02 30 31 31 435A 59 39 34 0D 0A

Correct response:**02 30 31 31 43 5A 59 4F 4B 34 38 0D 0A**

Wrong response:**02 30 31 34 43 5A 59 45 36 32 30 0D 0A** (channel no. error)

2) Input millivolt calibration zero in the chart (without weight)

Send command:

STX	Scale no.	Channel No.	C	ZN	Zero millivolt value	CRC	CR	LF
------------	-----------	-------------	----------	-----------	----------------------	------------	-----------	-----------

Correct response:

STX	Scale no.	Channel No.	C	ZN	O	K	CRC	CR	LF
------------	-----------	-------------	----------	-----------	----------	----------	------------	-----------	-----------

Wrong response:

STX	Scale no.	Channel No.	C	ZN	E	Error code	CRC	CR	LF
------------	-----------	-------------	----------	-----------	----------	------------	------------	-----------	-----------

Here:

ZN——2 bytes, **5AH4EH**

Zero millivolt value——6 bytes

For example:

02 30 31 31 43 5A 4E 30 31 32 36 31 30 38 31 0D 0A

Correct response:**02 30 31 31 43 5A 4E 4F 4B 33 37 0D 0A**

Wrong response: **02 30 31 31 43 5A 4E 45 34 30 34 0D 0A** (Write data error)

6.1.3.6 Gain calibration

1) With weights

Send command:

STX	Scale no.	Channel No.	C	GY	Weight value	CRC	CR	LF
-----	-----------	-------------	---	----	--------------	-----	----	----

Correct response:

STX	Scale no.	Channel No.	C	GY	O	K	CRC	CR	LF
-----	-----------	-------------	---	----	---	---	-----	----	----

Wrong response:

STX	Scale no.	Channel No.	C	GY	E	Error code	CRC	CR	LF
-----	-----------	-------------	---	----	---	------------	-----	----	----

Here:

GY——2 bytes, **47H 59H**

Weight value——6 bytes: Write in weight value

For example:

02 30 31 3143 47 59 30 30 30 32 30 30 36 35 0D 0A (Write in: weight value **200**)

Correct response: **02 30 31 31 43 47 59 4F 4B 32 39 0D 0A**

Wrong response: **02 30 31 35 43 47 59 45 36 30 32 0D 0A** (Channel no. error)

2) Without weights

Send command:

STX	Scale no.	Channel No.	C	GN	Gain millivolt	Weight value	CRC	CR	LF
-----	-----------	-------------	---	----	----------------	--------------	-----	----	----

Correct response:

STX	Scale no.	Channel No.	C	GN	O	K	CRC	CR	LF
------------	-----------	-------------	----------	-----------	----------	----------	------------	-----------	-----------

Wrong response:

STX	Scale no.	Channel No.	C	GN	E	Error code	CRC	CR	LF
------------	-----------	-------------	----------	-----------	----------	------------	------------	-----------	-----------

Here:

Gain millivolt—**6 bytes**

Weight value—**6bytes**

For example:

02 30 31 3143 47 4E 30 30 31 39 34 30 30 30 30 32 30 30 35 36 0D 0A (Write in: weight value **200**, corresponding gain millivolt **0.194**)

Correct response: **02 30 31 31 43 47 4E 4F 4B 31 38 0D 0A**

Wrong response: **02 30 31 31 43 48 4E 45 33 38 35 0D 0A** (Para. Code error)

6.1.3.7 Zeroing

Send command:

STX	Scale no.	Channel No.	O	CZ	CRC	CR	LF
------------	-----------	-------------	----------	-----------	------------	-----------	-----------

Correct response:

STX	Scale no.	Channel No.	O	CZ	O	K	CRC	CR	LF
------------	-----------	-------------	----------	-----------	----------	----------	------------	-----------	-----------

Wrong response:

STX	Scale no.	Channel No.	O	CZ	E	Error code	CRC	CR	LF
------------	-----------	-------------	----------	-----------	----------	------------	------------	-----------	-----------

For example:

02 30 31 31 4F 43 5A 38 34 0D 0A

Correct response: **02 30 31 31 4F 43 5A 4F 4B 33 38 0D 0A**

Wrong response: **02 30 31 31 4F 43 5A 45 35 30 36 0D 0A** (Operation can't execute)

6.1.3.8 CRC computation

All the values in front of the parity byte add together and convert to decimal data, then convert the last 2 bytes to **ASCII** code (decade in front and the unit at the back).

For example

The following is a frame of data:

02	30	31	31	4F	43	5A	38	34	0D	0A
----	----	----	----	----	----	----	----	----	----	----

Add 02~5A: 180(Hex), convert to decimal data: **384**. We can calculate from this that the check code is **38, 34** for the data frame.

6.2 r-Cont

Indicator will send weighing data to host computer without command.

Data Format:

STX	Scale no.	Channel no.	Status	Value	CRC	CR	LF
-----	-----------	-------------	--------	-------	-----	----	----

Here:

STX — 1byte, start character **02H**

Scale no. — 2bytes, **00~99**

Status — 2bytes, high byte: **40H**; low byte definition as follows:

D6	D5	D4	D3	D2	D1	D0
Null	Null	G./N. weight	+/-	Zero point	OFL	Stable
1	0	0: G 1: N	0: + 1: -	0: non/zero 1: zero	0: normal 1: OFL	0: not stable 1: stable

Weight Value — 6 bytes; when weight is+(-)overflow,return to“space space **OFL** space”

CRC — 2 bytes,check sum

CR — 1 byte, **0DH**

LF — 1 byte, **0AH**

For example:

02 30 31 31 40 41 20 20 20 37 30 30 (present weight) 32 34 0D 0A

Means: stable,positive data,present weight **700**

6.3 Modbus protocol

Modbus communication mode

RTU mode

When you use RTU mode to communicate, every 8-bit byte of the message are divided into 2pcs of 4-bit hexadecimal characters to transmit at binary code.

Data format: Select and set in communication parameters

Baud rate: **9600/19200/38400/57600**(optional)

Code: Binary

Function code:

Function code	Definition	Description
03	Read register	
06	Write single register	
16	Write several registers	Command only support write double registers.
01	read coil	The length unit is bit.
05	write coil	

Exception code response

Code	Definition	Description
02	Illegal data address	Data address received from error code is not allowed
03	Illegal data value	Data wrote in is not in permissible range
04	machine fault	When indicator is trying to execute operation required, unrecoverable error is produced.
07	Unsuccessful programming	Command received can't be executed under current condition.

request

6.3.1 Modbus communication address

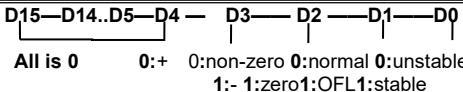
PLC addr.	Display addr.	Description
The following items are only-read register(code 0x03)		
40001	0000	Present weight value(4bits including sign characters, the high bit is in the front)
40002	0001	
40003	0002	 <p>All is 0 0:+ 0:non-zero 0:normal 0:unstable 1:- 1:zero 1:OFL 1:stable</p>
40004	0003	Reserve(permit to read, reading value is 0)
.....	
40006	0005	
The following items are two bytes and are available to read and write (write code 0x06, read code 0x03)		
40007	0006	Zeroing(zeroing when write in non-zero value)
40008	0007	Automatically zeroing when power on (0: OFF; 1: ON)
40009	0008	Zero tracking range (0-9d)
40010	0009	Stable range (1-9d)

40011	0010	Zeroing range (0%-99%)
40012	0011	Digit filter parameters(0-9)
40013	0012	Stability filter series(0-9)
40014	0013	AD sample rate: 0:120/s 1:480/s
40015~ 40018	0014~ 0017	Reserved
40019	0018	Decimal point place (0:0bit,1:1bit,2:2bits,3:3bits,4:4bits)
40020	0019	Minimum division (1/ 2/ 5/ 10/ 20/ 50)
The following items are available to read and write (writing code 0x10, read code 0x03)		
40021	0020	Maximum capacity (max.capacity≤mini.division×100000)
40022	0021	
40023	0022	Zero calibration with weights: write in 1 and calibrate zero with the current weight. Read: Absolute millivolt of current load cell
40024	0023	
40025	0024	Zero calibration without weights: Write millivolt value at zero; Write in range (load cell 3mV/V:millivolt value range within 0.02-12.000mV) millivolt value at zero when read.
40026	0025	
40027	0026	Gain calibration without weights; input gain millivolt(0.000

40028	0027	<millivolt< 20.000mV – zero millivolt).
40029	0028	Gain calibration with weights: input gain weight value (\leq Max. capacity)
40030	0029	
40031	0030	Gain point1 calibration with weight, input weight value (≥ 0 , \leq max. capacity)
40032	0031	
40033	0032	Gain point2 calibration with weight, input weight value (\geq gain point1, \leq max. capacity)
40034	0033	
40035	0034	Gain point3 calibration with weight, input weight value (\geq gain point2, \leq max. capacity)
40036	0035	
40037	0036	Gain point4 calibration with weight, input weight value (\geq gain point3, \leq max. capacity)
40038	0037	
40039~40040	0038~0039	reserved
40041	0040	Set point1 stable or not (0: no; 1: yes)
40042	0041	Set point1 min. duration time (0-999 : 0-99.9sec.)
40043	0042	Set point1 valid condition
40044~40045	0043~0044	Set point1set value 1
40046~40047	0045~0046	Set point1set value2
40048	0047	Set point2 stable or not (0: no; 1: yes)

40049	0048	Set point2min. duration time (0-999 : 0-99.9sec.)
40050	0049	Set point2 valid condition
40051~40052	0050~0051	Set point2set value1
40053~40054	0052~0053	Set point2set value2
40055	0054	Set point3 stable or not (0: no; 1: yes)
40056	0055	Set point3min. duration time (0-999 : 0-99.9sec.)
40057	0056	Set point3 valid condition
40058~40059	0057~0058	Set point3set value 1
40060~40061	0059~0060	Set point3set value 2
40062	0061	Set point4 stable or not (0: no; 1: yes)
40063	0062	Set point4min. duration time (0-999 : 0-99.9sec.)
40064	0063	Set point4 valid condition
40065~40066	0064~0065	Set point4set value 1
40067~40068	0066~0067	Set point4set value 2
40069	0068	Output 1 user-defined
40070	0069	Output 2 user-defined
40071	0070	Input 1 user-defined
40072	0071	I/O output value
40073	0072	I/O input value

Note: available only when coil address 00016 is valid.

			Input write 1 valid, 0 invalid. Read 1 valid, 0 invalid
40074	0073	Hold mode	0~4
40075	0074	Trigger condition	0~1
40076~40077	0075~0076	Trigger zerovalu e	0~999999
40078~40079	0077~0078	Hold result	Note: At peak hold, read the hold peak value; At valley hold, read the hold valley value. Others similar.
The following items are bit read only. (read code: 0x03)			
49001	9000	Version no.	If display 10024, format XX XXXX, main version no., hardware no., software no.. So main version no. 01, hardware no. 00, software no. 24
49002	9001		
49003	9002	Develop time	If display 141024, means 24 th Oct., 2014
49004	9003		

The following items are bit read only. (read code: 0 x 0 1)		
00001	0000	0: unstable; 1: stable
00002	0001	0: normal; 1: OFL
00003	0002	0: non-zero; 1: zero
00004	0003	0: +; 1: -
00005	0004	Reserved
00006	0005	Reserved
The following item are available to read and write (read code: 0x01, writing code: 0x05)		
00007	0006	Automatically zeroing when power on (0: OFF; 1: ON)
00008	0007	Setting trigger hold (Write: FF00H = ON, Note: can write ON only) Read: Trigger hold valid = 1; Trigger hold invalid = 0.
00009	0008	Reserved
00010	0009	Reset all
00011	0010	Reset calibration
00012	0011	Reset parameters
00013	0012	Reset I/O

00014	0013	Reserved	
00015	0014	Reserved	
00016	0015	I/O testing switch	
00017	0016	Set point 1 status	Only read: 0:invalid, 1:valid
00018	0017	Set point 2 status	
00019	0018	Set point 3 status	
00020	0019	Set point 4 status	
00021~ 00032	0020~ 0031	Reserved	

6.4 YH protocol

F2.3 When yH is selected, the data frame format (F2.4) is automatically adjusted to 8-N-1 and baud rate (F2.2) is automatically adjusted to 1200. The communication interval (F2.6) is automatically adjusted to 50ms.

In this protocol, data is output in ASCII format. Each frame consists of nine groups (including decimal points). Data transmission starts from low to high, and there is a group of delimiter "=" between each frame of data. The sent data is gross weight, for example, the current gross weight is 70.15, and the continuous transmission is 51.0700=51.0700...

For example: 123.9

Bit0	Bit1	Bit2	Bit3	Bit4	Bit5	Bit6	Bit7	Bit8
=	9	.	3	2	1	0	0	0

Here:





The high order is not enough to complement 0, the decimal point takes up 1 byte, and the negative number Bit8 is "-"

7 Password Input and Setting, Reset

7.1 Password Input

- (1) Indicator calibration and working parameters setting default password: **000000**.
- (2) User can set password in parameters when **F4.1** is "ON".
- (3) When display is "PASS", need to input correct password to enter parameters.

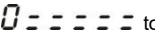
Note:

- (1) When input password, if first time wrong, it will go to the second chance for password input (display from  turn to ).
- (2) If second input wrong, it will enter into interface for inputting password the third time
(Display change from  to .
- (3) If Input wrong for three times, main display show "Error4" and self-lock, but user can operate when power on again.

7.2 Password Setting

- (1) User can set password in parameters when **F4.1** is "ON".

- (2) User must input same new password twice in setting password, If not same, main display show "**Error**" one second and return to **PASS** again.

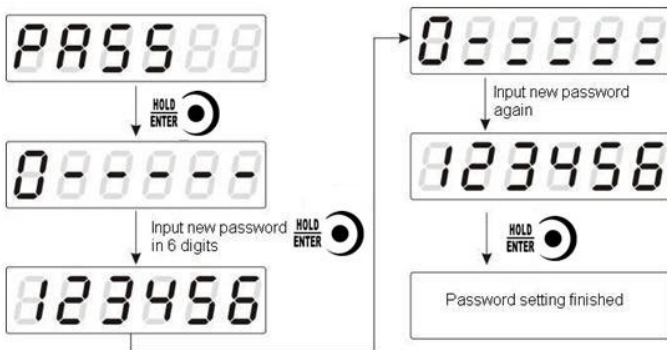

7.3 Factory Reset

Note: Factory reset is only for special technicians, which will reset all of parameters and will maybe cause not working.

Take reset all for example:

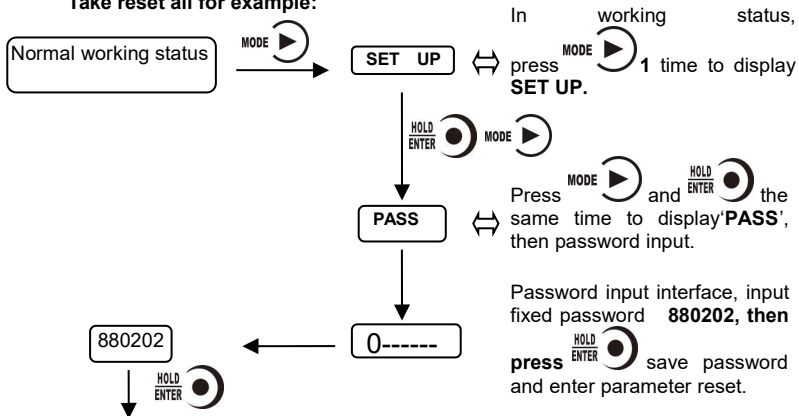

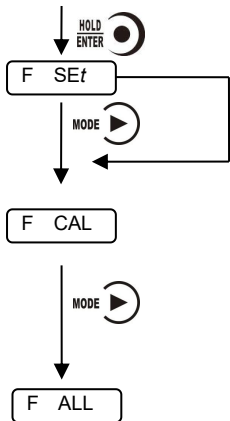

- 1) In **F SET** interface, press to reset working parameters, enter into reset calibration parameters interface.
- 2) In **F SET** interface, press , not to make working parameter reset, enter into calibration parameter reset interface.
- 1) In **F CAL** interface, press to reset calibration parameter, enter into reset all interface.
- 2) In **F CAL** interface, press , not to make calibration parameter reset, enter into reset all interface.
- 1) In **F ALL** interface, press to make reset all of the parameters (including working parameter, calibration parameter, I/O etc..).

Note: In all reset interfaces, press to exit and return to weighing interface.

8 Display Testing

The following flow chart is to test lights on main-display and status lights.

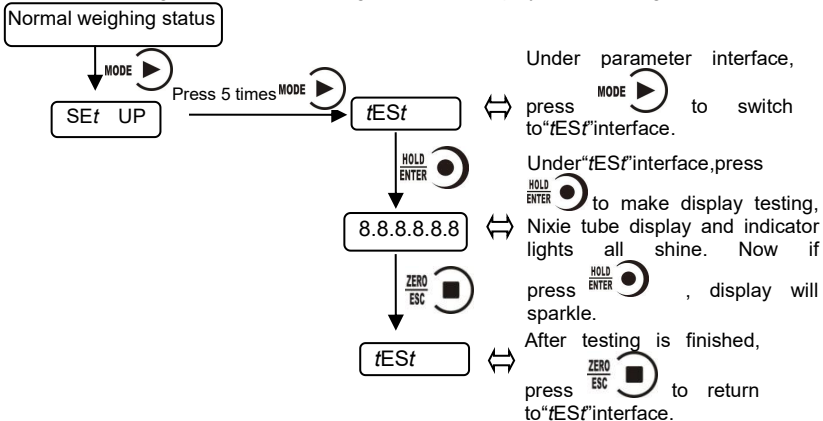

9 Errors and Alarm Messages

Error ① Input error.

② wrong data beyond parameter range.

Error 2 The present weight value is out of zeroing range.

Error 3 Scale platform is not stable when zeroing.

Error 4 Input wrong password more than 3 times.

OFL Weighing value is positive overflow.

-OFL Weighing value is negative overflow.

10 Dimension of Indicator

Dimension of rear panel: **92×45(mm)**

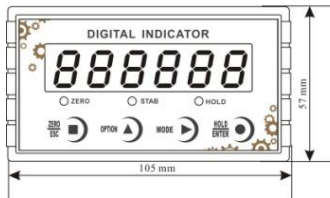
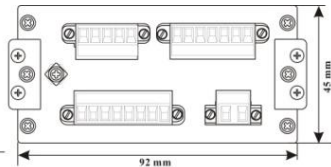

← Dimension of front panel: **105×57(mm)**

Panel cutout dimension: **93×46(mm)**

