

Mark Weigh
M1000
Weighing
Indicator

Manual

Menu

Chapter 1. Introduction.....	2
Chapter 2. Technical Parameters.....	2
Chapter 3. Installation.....	3
A. A diagram of the complete indicator	
B. The connection between the sensor and the indicator	
Chapter 4. Operational Methods.....	4
A. Starting-up	
B. Zero	
C. Time	
D. Tare Operation	
E. The storage and the clearing of data	
F. The operation of weighing printing	
G. Function of statistical printing	
Chapter 5. Setup of the connection of the printers.....	8
Chapter 6. Serial Communication.....	12
Chapter 7. Prompt of Information.....	13
Chapter 8. Notes.....	14
Chapter9.Appendix.....	14

Chapter 1. Introduction

Z18 weighing indicator with a high accuracy and a stable and reliable performance, can be formed into various kinds of electronic weighing system together with the sensor. It is widely used in many measuring situations including building sites, factories, docks, industrial enterprises and warehouses.

It can show the date, the time (uninterrupted in shutdown), the truck number (5 figures), the article number (5 figures) and the serial number. It can permanently memorize 200 pieces of tare data and temporarily stores 200 sets of data as well as 600 pieces of weighing data. The functions of it include daily report, monthly report, the statistics of truck numbers, the statistics of article numbers and the printing of truck tare lists. What's more, the statistical analysis of the truck numbers and the article numbers can be carried out according to the date or the month. With the power-off protection of data, it can be kept for a long time. In addition, it is equipped with a storage battery for emergency use in blackout, which means it will not be influenced by blackout. There are also other advantages of it. Inside of the indicator are an uninterrupted clock and RS-232C. The machine can connect to the indicator of the large screen and it can link to an external printer. And it can also link to the computer to use weighing management software computer.

Chapter 2 The Main Technical Performance

1. accuracy: III level
2. internal resolution: 1/50 million
3. performance of the sensor:
4. non-linear, hysteresis error of indicator: $\pm 0.02\%R.O$
5. creep: $\pm 0.025\%R.O$ 0/20 minutes
6. sensitivity: $2.02 \pm 0.004 Mv/v$
7. supply voltage: DC5V
8. AC power: AC220V (0%~10%) 50HZ \pm
DC power; DC6V storage battery
9. Power: $\leq 14.25W$
10. working temperature: weighing indicator
0°C-40°C
11. sensor: -20°C-40°C
12. relative humidity: 10-90%RH (but dew is not included)
13. the distance between the weighing indicator and the weighing platform: ≤ 30 meters
14. 8 \uparrow 350 Ω or 12 \uparrow 700 Ω sensors can be connected

Chapter 3. Installation

A. A diagram of the functions in the front and the back of the indicator

1. A diagram of the display window

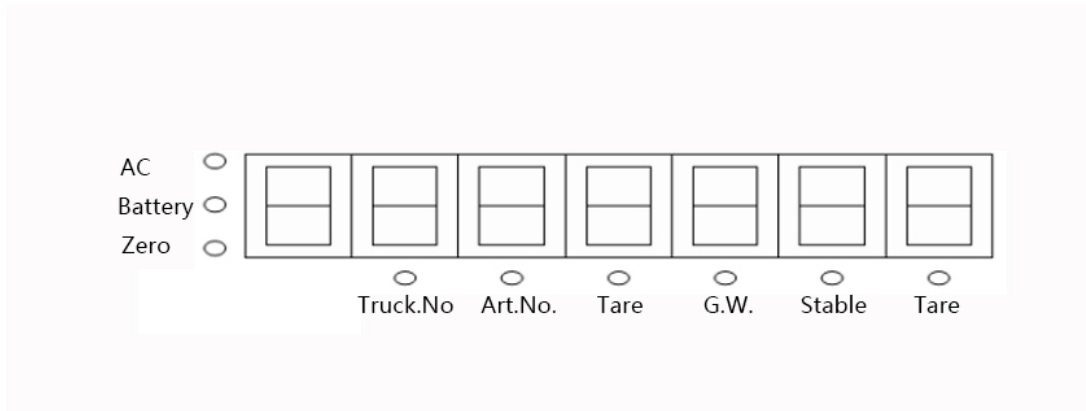

- When there is a truck number, the indicator of the truck number is on
- When there is an article number, the indicator of the article number is on
- When there are data of memorized tare, the tare indicator is on
- When there are temporarily stored data, the indicator of gross weight is on
- When the weighing is stable, the stable indicator is on
- When there is tare, the tare indicator is on; when use kilogram to be the measurement unit, the kg indicator is on
- When use AC power, the AC indicator is on

2. Keyboard Map

The keyboard layout of the indicator is showed in the diagram below, and as for the usage method, please refer to **An Introduction of Basic Operations**. (this product applies the menu entry access to operation)

Truck No	Func	1	2	3	Store Tare
Art No	Print Set	4	5	6	Input
Date	Accum Print	7	8	9	Weigh
Time	Add Print	Print	0 Preset Tare	Tare	Zero

B. The connection between the sensor and the indicator

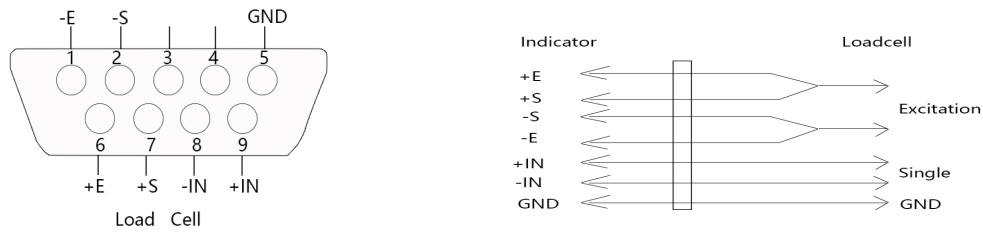

If a 4 core shielded cable is used, then +E and +S as well as -E and -S must be short-circuited.

C. The connection between the scoreboard and the indicator

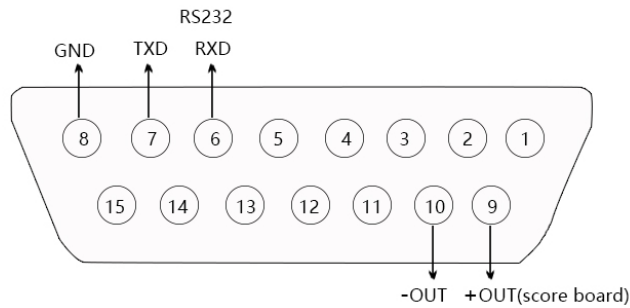

D. The connection between the printer and the indicator

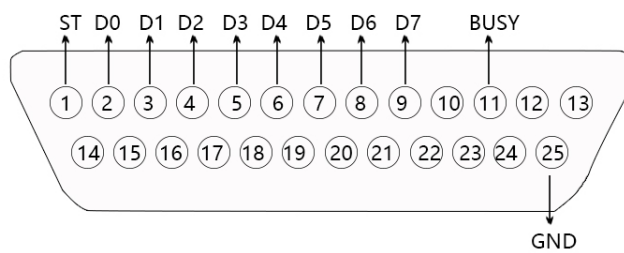

Chapter 4. Operational Methods

A. Starting-up

After the switch is on, the indicator carries out a self-checking of the stroke. When it finishes, the indicator enters into the weighing state. (The machine is equipped with a storage battery which is for an emergency use in blackout and please always plug in for an alternate use).

B. Zero

1. when the indicator is switched on, if the starting-up is within the zeroing range, then it will be automatically zeroed. (The range has been set according to regulations when it is out of the factory)

2. After the starting-up, if it is within the range of manual zeroing (The range has been set according to regulations when it is out of the factory) , then we can press the key [Zero] to carry out the manual zeroing.

C. Time (when there are errors in type-in, press 0 to clear the errors. Press the key [Weight] to exit the the weighing status.)

The correction of the system clock:

1. Correction of the date: press[Date] and directly type in the current date, then press[Input] to finish.

(for example: 170706, and it is typed in to be July 6, 2017)

If the number is typed in wrongly, press 0 to clear the mistake and until the indicator shows 0, type in [170706] again.

2. Correction of the time: press[Time] then directly type in the time and then press the key [Input] to finish it.

(There is a separate power supply in the time system of this product, which is unaffected by the blackout of the indicator.)

D. Tare

a. Taring of Material Objects

When gross weight > 0 and it is stable, press the “Tare” key, then the value of gross weight is deemed to be the current tare and the show value is zeroed. And at the same time the tare indicator is on.

b. Preset Tare (Digital Tare)

In the weighing state, press the [Preset Tare] key, and type in the tare value, then press [Input] key, and then the input data can be deemed as the current tare. At the same time, the tare indicator is on

c. Tare Clear

If the tare indicator is on, press the [Zero] key and clear the original tare. Then return to weighing and the “Tare” indicator is off.

E. The storage and the clearing of data

a. The storage of tare: (two methods)

1. The storage of weighing method: after an empty truck weighs on the scale, press the key[Store Tare], then press Truck. No. and press [Input]. The current weighing data can be restored and can be called in the future. (If there are any tare data kept before, this operation can renew them);
2. Digital input method: press [Truck. No.] first, then after typing in Truck. No., press [Input], and [P 00] is showed. Type in the tare data then press [Input].

b. The storage of truck numbers:

Type in the truck numbers: in the weighing status, press the key [Truck. No.], and the original truck number is showed. After typing in the truck number, then press[Input], and the indicator of the truck number is on. Then press [Weight] to return to the weighing status.

c. The storage of article numbers:

Type in the article numbers: press the key[Art. No], and the original article number is showed. After typing in the article number, press the key[Input] and the indicator of the article number is on. Then return to the weighing status.

Clear the data in the memory: (use with caution)

In the weighing status:

Press the key [Print Setup] and type in [72] and then press the key [Input] to clear all the weighing data, then “clear” will be showed;

(note: the weighing data are data which have been printer, i.e. data in the database; the tare data refer to memorized data.)

F. Operation of weighing printing

The operation diagram of weighing printing:

One of the methods can be chosen to carry out the printing according to different situations and the operation is showed in the chart below. A heavy truck weighs on the scale and after printing the data for once, the [Print] key cannot be pressed again otherwise the contents of the supplementary print will be cleared.

A. Weighing printing finished in one time:

1. Only print the gross weight of the truck

steps	operation	Contents showed	explanation
1	A heavy truck weighs on the scale (wait for the stable indicator to be on)	press[print]	[c *****] The original truck No. is showed
2	Type in "0"(must)	press[0]	'0' means goods being weighed
3		press[Input]	[H *****] Show the original Art. No.
4	Type in Art. No.	press [11]	[H 11] If don't want to change,

				directly press [Input]
5		press[Input]	[Print]	print

2. (the tare mode of material objects) print the gross weight, tare and the net weight of the truck

steps	operation	Contents showed	explanation	
1	An empty truck weighs on the scale (wait for the stable indicator to be on)	press[Tare]	[0]	The tare indicator is on
2	A heavily loaded truck weighs on the scale (wait for the stable indicator to be on)	press[Print]	[c *****]	Show the original Truck. No., and show 0 when there is no Truck. No
3	Key in Truck. No.	Type in the truck number, press [Input]	[c *****]	Input the Truck NO.
4		Type in Art. No. And press[Input] such as 01	[H ***]	Show the original Truck. No., and show 0 when there is no Truck. No
6	Key in Art. No.		[H ***]	Input Art. No.
7	print	press[Input]	PRINT	print the weighing data sheets
8			Weighing value	After printing, remove the weight from the car and press [Tare] to return to zero

3. (the tare of the truck is known and preset the tare mode) Print the gross weight, the tare and the net weight of the truck

steps	operation	Contents showed	explanation	
1	A heavy truck weighs on the scale (wait for the stable indicator to be on)			Show the weight
2	Type in tare	press[Preset Tare]	[t ***]	Show the original tare
		Type in tare, press[Input]	****	Show the weight after taring
3		press 【Print】	[c ***]	Show the original Truck. No., and show 0 when there is no Truck. No
4	Key in Truck. No.	Type in Truck. No.	[c ***]	Input the Truck No.
5		press[Input]	[H *****]	After confirming the Truck. No. show the original Art. No. And show 0 when there is no Art. No.
6	Key in Art. No.	Type in Art. No., e.g. 01	[H 01]	Input the Art No
7		Press [Input]	PRINT	print the weighing data sheets
			Weighing value	After printing, remove the weight from the car and press [Tare] to return to zero

4. (the tare mode of calling memory) print the weighing data sheets

steps	operation	Contents showed	explanation	
1	A heavy truck weighs on the			Show the weight

	scale (wait for the stable indicator to be on)			
2		press 【Truck. No.】	[c *****]	Show the original Truck. No. And type in the corresponding Truck. No. In time
3	Key in Truck. No. (must)	Type in Truck. No.	[c *****]	Truck. No.
4		press[Tare]		Minus the stored tare and then show the weight after taring
5		press[Print]	[H ****]	Show the original Art. No.
6	Key in Art. No.	Type in Art. No.	[H ****]	Show Art. No.
7	print	press[Input]	PRINT	print the weighing data sheets
8	The truck if off the scale, and there are negative numbers on the sheets	press[Tare]	[0]	Weighing status

B. The two-time stored weighing printing:

The printing is carried out when a set of complete weighing data is finished by two times, and press [Print] to enter into weighing storage. When in the storing process, the system will automatically check whether it is the second time of weighing storage for the Truck No. and if it is the second time, the weighing data will be calculated, printed and stored into the statistical data base, releasing the storage room by cleaning the temporarily stored data of this truck number; if it is not the second time, then [good] will be showed and it returns to weighing, and in this way the first storage is finished.

steps	operation	Contents showed	explanation	
1	A truck weighs on the scale (wait for the stable indicator to be on)	press[Print]	[C *****]	Show the original Truck. No.
2	Type in the new Truck. No.	Such as [80088]	[C 80088]	Directly press[Input] if there is no correction
3		press[Input]	[H ***]	Show the original Art. No.
4	Type in the new Art. No.	[099]	[H 099]	Directly press[Input] if there is no correction
5		press[Input]	[good]	When the storage is finished for the first time, it will return to weighing after a few seconds to wait for the second time
			If it shows[Print]	Show that it has been the second time for the weighing and it enters into printing automatically

C. Supplementary print

1. **Supplementary print:** for example, if something is out of order during the process of printing, please directly press this key after the faults are removed to print the weighing measurement list of the last time;

Explanation :(data below the truck No. (gross weight and net weight)), after a complete storage,a set of weighing data will be calculated. After press the printing key, the weighing data will be printed while the data will also be restored into the database space for statistical printing. It means that only those weighing data which have been printed will appear in the data base while the storage space of temporarily stored data of the current truck No. And the temporarily stored data will disappear. (On the indicator, the gross weight indicator refers to temporarily stored data; the tare memory will be restored in a database space forever until they have been removed by human.)

G. function of statistical printing

After printing, this system will store the weighing data which have been printed, then can count

(1) Statistics of truck No.

statistics of truck No.: long press the key [Truck. No.], then “tru-rp” will be showed, then press “Truck. No” and press the [Input] key and “in-t” is showed. Type in the dates needed to be counted (YYMMDD form, such as: 050615) or the months (YYMM forms such as: 0506). It is consented to be today if the date is not typed in and press directly the [Input] key;

- a) Type in the date in the form of (YYMMDD): print all the weighing measurement sheets of the truck No. of the date typed in. If the date is not typed in, then print the data of the day. (If it is a micro-printer, print the daily accumulated values of the article No.of the date and if directly press the key [Input], then the daily accumulated values of the article No. are printed.)
- b) Type in the month in the form of YYMM: print all the weighing measurement sheets of the truck No. of the month typed in. (If it is a micro-printer, print the monthly accumulated values of the truck No.of the month and if directly press the key [Input], then the daily accumulated values of the article No. are printed.)

7

(2) The statistics of Art. No.

the statistics of Art. No.: long press the key[Art. No.], then “CAr-rp” is showed. Type in “Art.No.” and press the key [Print] and “in-t” is showed. Type in the dates needed to be counted (YYMMDD form such as: 050615) or the months (YYMM form such as: 0506). It is consented to be today if the date is not typed in and press directly [Print];

- a) Type in the date in the form of (YYMMDD): print all the weighing measurement sheets of the article No. of the date typed in. If the date is not typed in, then print the data of the day. (If it is a micro-printer, print the daily accumulated values of the article No.of the date and if directly press the key [Input], then the daily accumulated values of the article No. are printed.)
- b) Type in the month in the form of YYMM: print all the weighing measurement sheets of the article No. of the month typed in. (If it is a micro-printer, print the monthly accumulated values of the

article No.of the month and if directly press the key [Input], then the daily accumulated values of the article No. are printed..)

(3) Daily report

Print the daily report: long press the [Time] key and it shows“day-rp”. According to the YYMMDD format, type in the date needed to be printed (it is consented to be today if the date is not typed in), press [Print], and all the weighing data from 0 o’clock to 24 o’clock of the date will be accumulated and printed. (If it is a micro-printer, the daily accumulated value of the day should be printed and if directly press the key [Input] then all the daily accumulated values of the day will be printed).

(4) The list of memorizing tare

the list of memorizing tare: long press the key[Store Tare], and the printer will print automatically all the stored data of the memorized tare.

Chapter 5. Setup of the printers

Attention: only one type of printer can be used when the indicators are under the same setting.

Micro-print and the external printer cannot be used at the same time.

1.Setup of the printer

steps	operation	Contents showed	explanation
1	press[Print Setup] press[9][7] press[Input]	[P 00] [P 97]	Type in the password 97
2	press[0] press[Input]	[auto *] [auto 0]	Choose manual printing and automatic printing 0---manual printing 1---automatic printing
3	press[2] press[Input]	[TYPC *] [TYPC 2]	Choose the printer 2— Panasonic KX-P1121 3—Built-in micro-print 5—EPSON 300K+ 6—Thermal printer POS58 E.g.: choice 2 KX-P1121
4	press[0] press[Input]	[HL **] [HL 0]	Set up a print limit when printing again, the range being 00-99 00---zero print 25---the weight is back to 25% of the full weighing --- 99---the weight is back to 99% of the full weighing

5	press[0] press[Input]	[ode *] [ode 0]	Choose the print format odE=1 1 filling print odE=0 1 weight note print e.g.: choose 0
	press[3] press[Input]	[Arr *] [Arr 3]	Choose the print format Arr=1 1 copy sheets Arr=2 2 copy sheets Arr=3 3 copy sheets E.g.: choose 3
6	press[50] press[Input]	[L *****] [L 50]	Set up the minimum automatic print weight and the minimum must be 10d
7	press[2][0] press[Input]	[b **] [b 20]	Set the row number of chart drive (0-30) (it is set up according to the needs when using micro-printer) such as: 20
9	press[1] press[Input]	[LAnG *] [LAnG 1]	Choose printing control language LAnG=0 0 English LAnG=1 1 Chinese E.g.: choose 1
10	press[10011] press[Input]	[Y *****] [Y10011]	Y.10011--- print for the first time Y.10001--- not print the Art. No. Y.10000--- not print the Truck. No.and Art. No. Y.10101---print the tons (t) Y.00011----print for the second time Y.00001--- not print the Art. No.
11	[Z-00100] press[Input]	[Z-00100]	00100 -When printing , the net weight is printed as gross weight and the tare weight is 0 00000 -When printing a weighing, print the gross weight
12	[FIL 0] press[Input]	[FIL 0]	Filling print format, choose 0-7

Attention: only one type of printer can be used when the indicators are under the same setting. Micro-print and the external printer cannot be used at the same time. An adjustment of the color shapes of micro-print:

Press the key[Print Setup], then press[7777X], X=[0~9], and then press [Input] to make confirmation. The last number stands for the color shapes with the color of a small number being light while the color of a big number being dark. (default value of X is 7)

Appendix: (the format of the weighing sheet)

Print the serial number, the truck No., the article No., the date, the time, the tare, the gross

weight as well as the net weight of the weighing this time; at the same time store the data of the weighing this time.

The data which are basically printed include the serial number, the date, the time. If there are no data of the truck No., the article No., the tare, the gross weight and the net weight and then they will not be printed out.

The Chinese format of the weighing measurement sheet of a micro-printer:

<p>Weighing sheet ***** Serial No: 1 Date: 05/06/07 Time: 10:45:45 Truck. No.: 846312 Art. No.: 123456 Gross weight: 5000kg Tare: 1600kg Net weight: 3400kg TEL:12345678</p>
--

Weighing sheet (the second copy)					
Name of the company:					
Serial number	1	Truck. No.	123456	tare	1500kg
Art. No.	35	date	2008-6-4	Gross weight	4500kg
		time	19:38	Net weight	3000kg
Weighing sheet (the first copy)					
Name of the company:					
Serial number	1	Truck. No.	123456	tare	1500kg
Art. No.	35	date	2008-6-4	Gross weight	4500kg
		time	19:38	Net weight	3000kg
note:					

Chapter 6. Serial Communication

A. Communication : (serial RS232 output)

1. The format of serial data:

(1).transmission mode: 1 start bit, 8 data bits, 1 stop bit, no parity check bit;

(2).baud rate: one type of 1200, 2400, 4800, 9600;

The format of data (0): TF=0

XON、SIGN、X6、X5、X4、X3、X2、X1、POINT、CKFH、CKFL、XOFF;

explanation:

- a. XON : sigh of starting 02H
- b. SIGN : sigh bit (+/—)
- c. X6~X1: show the weight values (no decimal point)
- d. POINT: places of decimal points (from right to left0-3)
- e. CKFH: high-order bit of Block Check Character (ASCII)
- f. CKFL: low-order bit of Block Check Character (ASCII)
- g. XOFF: sigh language of ending 03H

Note: XOR= (SIGN) Xor(X6) Xor (X5) Xor (X4) Xor(X3) Xor(X2) Xor(X1)Xor(POINT)

Protocol 2; TF=2

Old D2+continuous communication format, data output in ASC II code, with 8 bytes per frame (including decimal points). The data is transmitted from low to high, and the frames are divided by "=" . Sending data as net weight (i.e. instrument display value), if the current instrument display value is 70.15, the instrument will continuously send 51.0700=51.0700=51.0700

Protocol 3; TF=3

The new D2+continuous communication format outputs data in ASC II format, with 9 bytes per frame (including decimal points).

The data is transmitted from low to high, and the frames are divided by "=" . Send data as net weight (i.e. instrument display value), such as when

If the displayed value on the front instrument panel is 70.15, then the instrument panel will continuously send 51.07000=51.07000=51.07000

Protocol 4; TF=4

.data format (4): STX、SA、SB、SC、X6、X5、X4、X3、X2、X1、T6、T5、T4、T3、T2、T1、CR、CKF;

explanation: a. STX sigh bit of starting (02h)

b. SA status word

(high)

(low)

0	1	1	1	1	D2	D1	D0
---	---	---	---	---	----	----	----

	D2	D1	D0	override
	0	0	1	*10
	0	1	0	*1
	0	1	1	*0.1
	1	0	0	*0.01

C. SB status word

(high)

(low)

0	0	1	kg	unstable	overflow	negative	Net weight
---	---	---	----	----------	----------	----------	------------



- d.SC status word (backup)
- e.X6~X1: show the weight (gross weight or net weight) and send the high-order first (no decimal point)
- f.T6~T1: tare, send the high-order first (no decimal point)
- g. CR sigh bit of ending (0dh)
- h.CKF is check bit (not used at present and is a fixed value 80H)

2、 A diagram of connection of serial ports

A .DB-15 pin connector is used by RS-232C and the interface of the large screen.

(1) The definition of connecting pins:

pin	7	8	9	10
definition	RS232C TXD	RS232C GND	Signals of the large screen OUT+	Ground of the large screen GND

B. Setup of the baud rate

Step	Operate	Show	Explain
1	Press[Set]	In the weighing display state	
2	Press[9][8] Press[Input]	[P 00] [P 98]	Input the password "98"
3	Press[1] Press[Input]	[b t *] [b t 3]	Baud 0--1200 1--2400 2--4800 3--9600
4	Press[0] Press[Input]	[t F *] [t F 0]	Serial communication method: 0-- Continuous sending without receiving 1--Hold on 2--Old D2+continuous communication format, 8 bytes per frame 3--New D2+continuous communication format, 9 bytes per frame 4.-- format4
5		Weighing status	Communication parameter setting completed

Chapter 7. Prompt of Information

1	ERR 01	No printer or the print setup is wrong
2	ERR 02	Errors in input data types
3	ERR 03	Errors in input data values
4	ERR 04	The memory is damaged
5	ERR 07	There have been more than 1500 pieces of the weighing data and please clear them.
6	ERR 08	There have been more than 200 pieces of truck tare and please clear them.
7	ERR 09	There have been more than 200 pieces of the temporarily stored data and please clear them
8	Err 11	A wrong connection of the buses or of the sensor's signal wires; the sensor or the connecting box is damaged.
9	No	The operation fails
10	yes	The operation is successful
10	clear	Clear data
11	print	In printing
12	8.8.8.8.8.8.	Please charge the battery because of low power
13	Err 05	The days for the machine locked expire and please contact the dealer
14	Full	Prompt of overload (bigger than the maximum ranger+8d)

Chapter 8. Notes

- a. Please use 220V50Hz AC power in normal use, and the power supply must be earthed strictly otherwise the neutral line will be electrified to damage the weighing indicator. Therefore the frequent use of a storage battery in the machine must be forbidden. When the weighing indicator shows Bt=0, please plug in 220V50Hz AC power. Otherwise the lifespan of the storage battery will be shorten seriously or the storage battery will be damaged because of over-discharging.
- b. If some abnormalities are showed, such as 888888, shining, beeping or no displaying, they may be caused by the power lacking of the storage battery and please charge the battery.
- c. If some abnormalities appear during the operation, please turn off the machine and start it again.
- d. The scale body must be installed on a solid basis. After finishing the installation and the calibration, welding operation must not be carried out on the scale body in the use. Electric cables of high voltage and large current must not pass through the scale body.

- e. The environmental temperature for the use of the controlled indicator is 0°C-40°C. And to ensure a clear display of the numbers, please avoid using it directly under the sun. When use it again after a long period of time, please preheat the machine more than 15 minutes.
- f. It cannot be used in place with a high temperature, high dust , corrosive air and a severe vibration.
- g. Strong solvents such as benzene and the nitro-oil to clean the machine case.
- h. Water must not be infused into the machine, otherwise there will be danger of burning the indicator as well as electric shock. The indicator must be earthed well. Stay away from a strong magnetic field. The sensor and the indicator must stay away from strongly corrosive materials as well as inflammable and explosive materials.
- i. After the weighing apparatus is inspected, the user cannot alter any calibrated data by himself/ herself.

The indicator should be used in places where lightning strikes can be prevented. Any natural disasters including lightning strikes are not covered by warranty.

- j. Within one year from the day of sale, if there are errors in the D8 model weighing controlled indicator sold by our factory not due to human factors when it is used correctly, this situation is covered by the warranty. If the user unseals the factory seal on his / her own, the user has to pay the repair fee even it is still under warranty.

The storage battery is for an emergency use in case of blackout and therefore the storage battery is not covered by warranty