

Mark Weigh MK530 Weighing Controller Users manual



list

1、 overview	1
2、 front and rear panel.....	3
2-1、 Interface description	3
2-2、 rear panel	5
3、 general function guide.....	6
3-1、 function setup and operation procedure	6
3-2、 parameter setting key effect.....	6
3-3、 function setting	7
4、 calibration	11
5、 check weighing configuration	16
6、 cable connect manual.....	17
6-1、 power.....	17
6-2、 Load cell.....	17
6-3、 serial port	17
6-4、 analog output	17
6-5、 relay output	18
6-6、 input	19



1、 overview

Hardware construction:

power supply: 24vDC

load cell excitation voltage: 5vDC \pm 5%

load cell number: up to eight 350 Ω

load cell sensitivity: 0~3.0mv/v

load cell connections: six wire

keyboard: six key

display: six digits red 7 segment LED display

operating temperature range: -10~40 $^{\circ}$ C

relay output: 4 output, AC250v 5A

input: isolation voltage 2500V

analog output: 4~20mA/0~5v

serial port: RS232/RS485, baud rate 600~19200bit/s

Software feature:

Max sampling speed: 120SPS

AD digital filter

digital calibration

batching or dosing functions

Dimension:

housing dimension: 92*45mm

front panel dimension: 102*55mm

trepanning dimension: 93*46mm



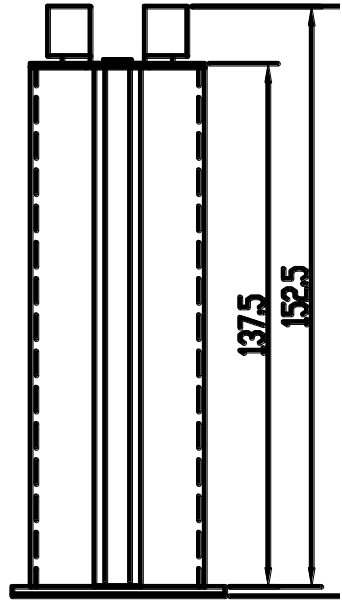
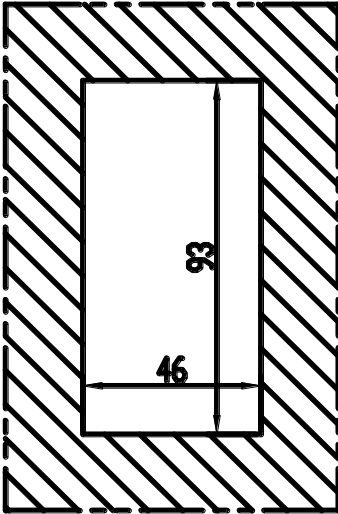
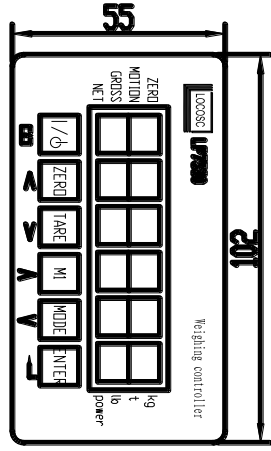
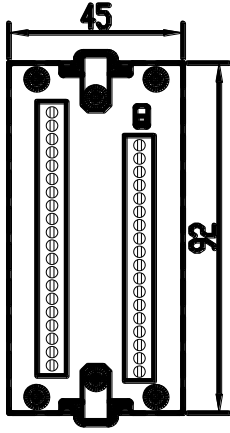

2、 front and rear panel

2-1、 Interface description

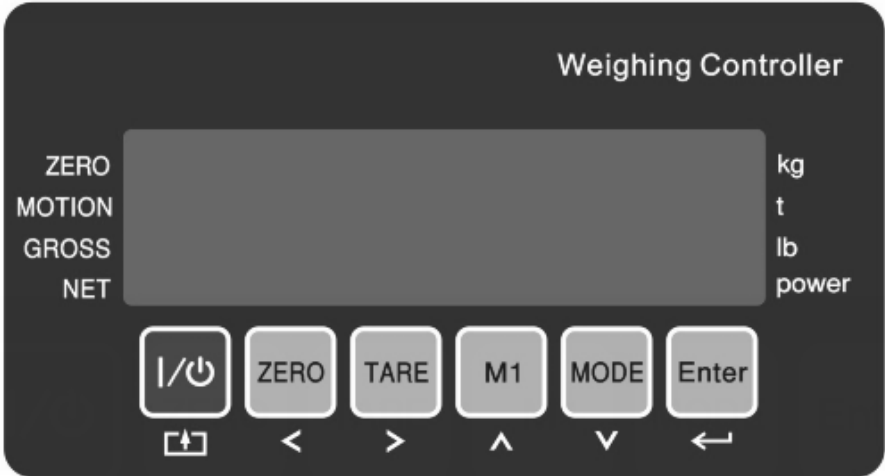

six digits red 7 segment LED display, high 0.4''

ZERO: zero indication

MOTION: unstable weight indication

GROSS: gross weight indication

NET: net weight indication

kg: kg unit

t: t unit

lb: lb unit

power: indicate power on when off





power down or power up

ZERO

zero operation

TARE

semi-auto tare operation

M1

display gross/net weight

MODE

setpoint parameter set

Enter

enter key



2-2、 rear panel

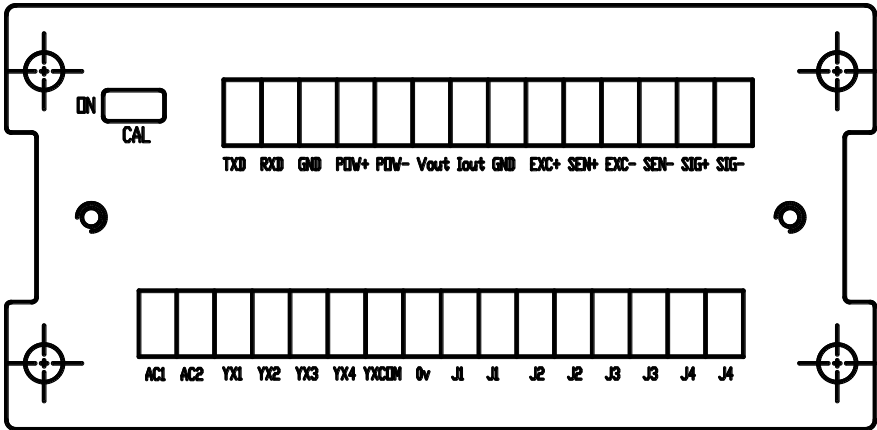

Connect definition:

power: POW+ POW- for 24VDC, AC1 AC2 for 220VAC

load cell: EXC+ SEN+ EXC- SEN- SIG+ SIG-

serial communications: TXD RXD GND for RS232, A B for RS485

analog output: Vout Iout GND









relay output: J1 J1 J2 J2 J3 J3 J4 J4

input: YX1 YX2 YX3 YX4 YXCOM 0v



3、 general function guide

3-1、 function setup and operation procedure

function	operation	display	remark
enter calibration mode	turn the calibration switch to “ON”	01 CSP	4
enter function setting	weight mode, press  and 	01 FnC	3.3
check weighing setpoint parameter setting	weight mode, press 	1.FinAL	5
enter to test mode	turn power on, press  and 	1. dsp	7.1
reset all parameters back to default	turn power on , turn the calibration switch to “ON”, press  and 	i.ALL	7.2
reset general function parameters back to default	turn power on, press  and 	1 FnC	7.2

3-2、 parameter setting key effect



it means “esc”



move the flashing digit left



move the flashing digit right



increments the flashing digit or steps up the select item





decrements the flashing digit or steps down the select item





confirm





3-3、function setting

Press  and  go into function setting, display “01 FnC” function setting;

press  , display “02 232” serial port interface;

press  , display “03 Sq ” weight comparison procedures;

press  , display “04 AnL” analog current output;

press  , display “05 In ” external input interface;

press  , go into the next level menu;

press  , save and out this menu, restart.

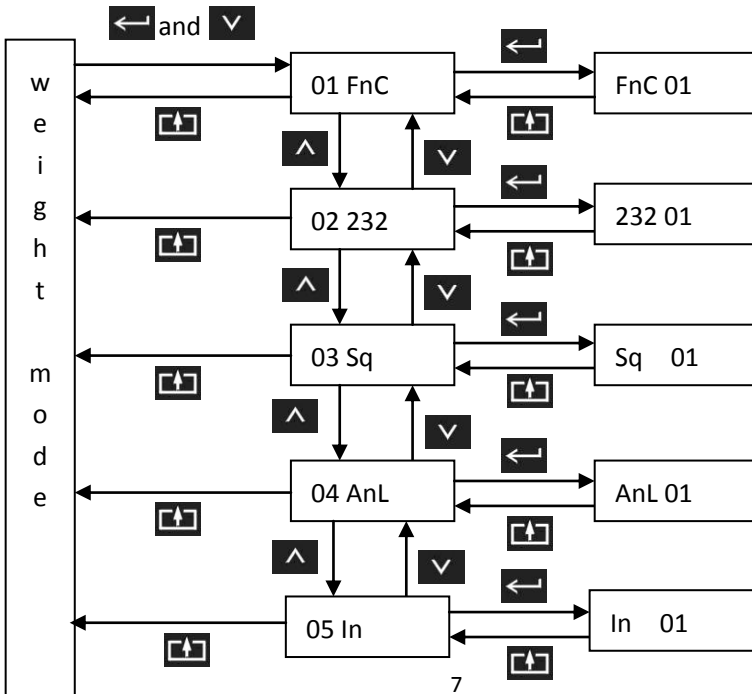

“01 FnC” function parameter code

function	item	parameter	description	default
digital filter 1	FnC 01	=00	greater	03
		=01	↓	
		...		
		=10	less	
digital filter 2	FnC 02	=00	less	02
		=01	↓	
		=02		
		=03	greater	
rate for display rewrite	FnC 03	=01	1 times/sec	10
		=05	5 times/sec	
		=10	10 times/sec	
		=20	20 times/sec	
		=120	120 times/sec	

“02 232” serial port interface

function	item	parameter	description	default
baud rate	232 01	=00	600bit/s	04
		=01	1200bit/s	
		=02	2400bit/s	
		=03	4800bit/s	
		=04	9600bit/s	
		=05	19200bit/s	
transmit mode	232 02	=00	close serial port	01
		=01	continuous	
		=02	print mode	
		=03	stable send	
		=04	command mode	
data format	232 03	=00	format 1	00
		=01	format 2	
		=02	print format	



transmit time	232 04	=00 =01 =02 =03	open 1 sec 2 sec 5 sec	00
address for multicomputer	232 05	00 01~99	only one address (bcd)	00



“03 Sq ” weight comparison procedures

function	item	parameter	description	default
batching mode	Sq 01	=01 =02 =03 =04	normal batch less-in weight comparison	01
control mode	Sq 02	=01 =02 =03	manual start auto for custom	01
comparison format	Sq 03	=01 =02	net gross	01
start delay	Sq 04	=00 =01 ... =10	no delay 1 sec delay ... 10 sec delay	01
stable time	Sq 05	=00 =01 ... =10	no wait 1 sec wait ... 10 sec wait	03

“04 AnL ” analog current output

function	item	parameter	description	default
signal output	AnL 01	=00 =01 =02	4~20mA current 0~20mA current 0~5v voltage	00
data	AnL 02	=00	display weight	00



format		=01	gross weight	
weight in Hi	AnL 03	010000	when max analog output weight	010000
zero adjust	AnL 04	4mA/0mA/0v	press  or 	4
linearity adjust	AnL 05	20mA/5v	adjust output	20
output range limit	AnL 06	=00 =01	no limit limit	00

“05 In ” external input interface

function	item	parameter	description	default
INPUT1	In 01	=00	no function	01
INPUT2	In 02	=01	zero	02
INPUT3	In 03	=02	tare	05
INPUT4	In 04	=03 =04 =05 =06	gross hold total print	06



4、 calibration

Weight mode, calibration switch set to “ON”, display “01 CSP” calibration parameter code;

press , display “02 CAL” general calibration;

press , display “03 CUo” sensitivity calibration。

press , go into next level step;

calibration end, calibration switch set to “OFF”, display “End ” save data, restart。

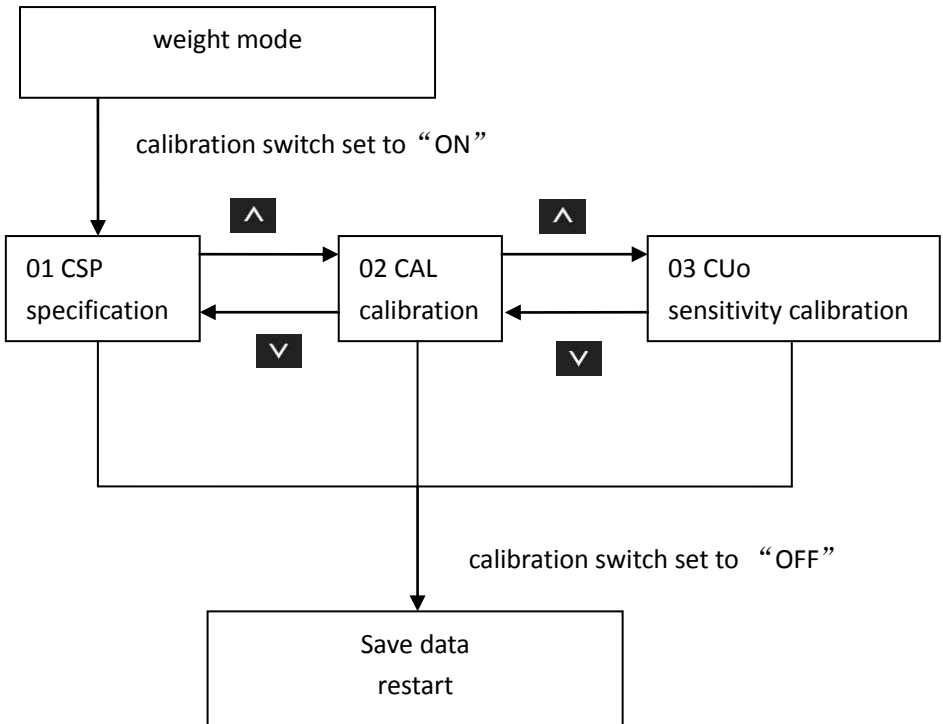

“01 CSP” calibration parameter code

function	item	parameter	description	default
unit	CSP 01	01	kg	01
		02	lb	
		03	t	
decimal point	CSP 02	00	none	00
		01	1decimal point	
		02	2decimal point	
		03	3decimal point	
division	CSP 03	01	division size	02
		02		
		05		
Max capacity	CSP 04	010000	Max capacity	10000
zero-setting range	CSP 05	00	0	02
		01	±1%	
		02	±2%	
initial zero-setting range	CSP 06	00	0	10
		01	±1%	
		02	±2%	
		05	±5%	
automatic zero-setting range	CSP 07	00	0	05
		05	0.5d	
		10	1d	
		20	2d	
automatic zero-setting time	CSP 08	00	0	01
		01	1sec	
		02	2sec	
		03	3sec	





stable time	CSP 09	00 01 02	fast medium slow	01
stable range	CSP 10	01 02 05 10	1d 2d 5d 10d	02
automatic zero	CSP 11	00 02 05 10 20	no -2d -5d -10d -20d	02
preserved menu	CSP 12			





“02 CAL” calibration

weight mode calibration switch set to “ON”

calibration press 

go into calibration press 

zero calibration press 

skip zero calibration 

display zero code

3 seconds

weight calibration press 

skip weight calibration 

use     set weight

weight stable, press 

sensitivity

3 seconds, calibration done

set calibration switch to “OFF”

finish

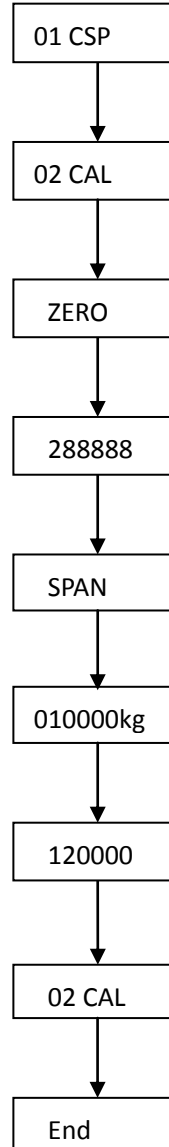



note: zero calibration no more than 5mv.



“03 CUo” sensitivity calibration
weight mode calibration switch set to “ON”

sensitivity calibration press 

go into calibration press 

zero calibration press 

skip zero calibration 

auto gather zero code

or press  set zero code

enter zero calibration 

sensitivity calibration press 

skip sensitivity calibration 

use     set sensitivity

enter press 

sensitivity calibration done

set calibration switch to “OFF”
finish

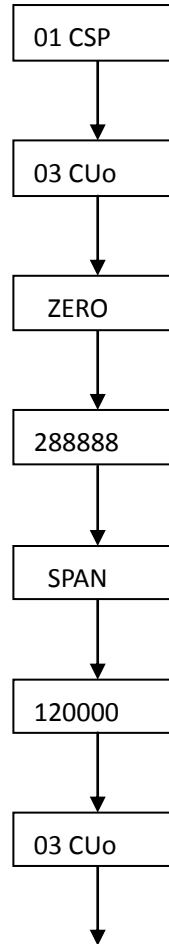

sensitivity = $100000 \times \text{load cell full scale output} \times \text{weighing meter capacity} /$
(N * Load cell capacity),



5、 check weighing configuration

weight mode press  go into parameter

display	function
1.FinAL	final value
2.SP1	SP1 value
3.SP2	SP2 value
4.SP3	SP3 value
5.F.FALL	free fall value
6.oUEr	over value
7.UndEr	under value
8.Z.bAnd	zero band

warning: set FinAL >SP1>SP2>SP3> F.FALL

set Sq01=1: net weigh

signal	output condition	Relay output
SP1	$\text{Net} \geq \text{Final-SP1}$	J1
SP2	$\text{Net} \geq \text{Final-SP2}$	J2
SP3	$\text{Net} \geq \text{Final-SP3}$	J3
Free fall	$\text{Net} \geq \text{Final-F.FALL}$	J4

Set Sq01=3:

signal	output condition	Relay output
HI	$\text{Net} > \text{SP1}$	J1
OK	$\text{SP1} \geq \text{Net} \geq \text{SP2}$	J2
LO	$\text{Net} < \text{SP2}$	J3



6、cable connect manual

6-1、power

POW+ 24VDC+

POW- 24VDC-

AC1 220VAC

AC2 220VAC

6-2、Load cell

EXC+

SEN+

EXC-

SEN-

SIG+

SIG-

NOTE: use 4-wire load cell need EXC+ and SEN+ short connect, EXC- and SEN- short connect。

6-3、serial port

TXD RS232 transmission

RXD RS232 receive

GND RS232 GND

A RS485 A

B RS485 B

6-4、analog output

Vout 0~5v voltage, load more than 1k Ω

Iout 4~20mA current, load span 100~500 Ω

GND GND



6-5、 relay output

J1 J1 first group relay output

J2 J2 second group relay output

J3 J3 third group relay output

J4 J4 fourth group relay output

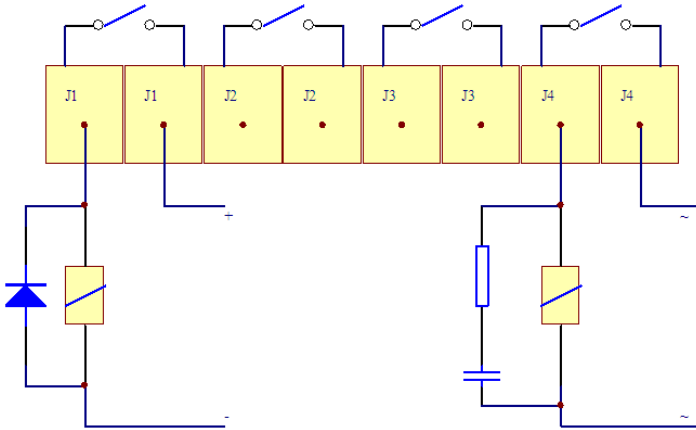

Relay output connection diagram

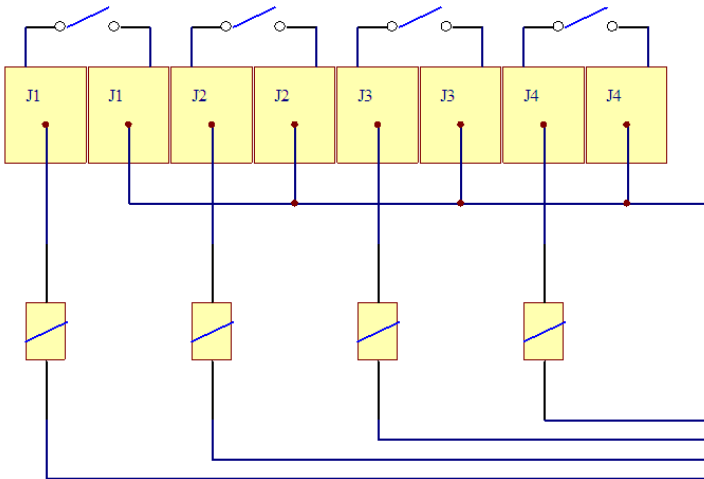

Common connection diagram

neto: use common connection, put one of J1, J2, J3, J4 short connect.



6-6、input

- YX1 first group input
- YX2 second group input
- YX3 third group input
- YX4 fourth group input
- YXCOM input common
- 0v out connect power GND

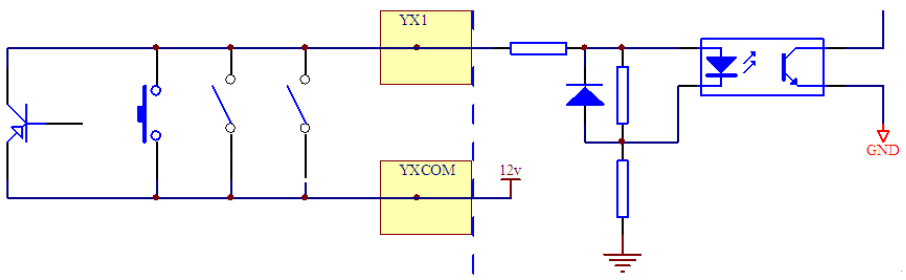

Input diagram

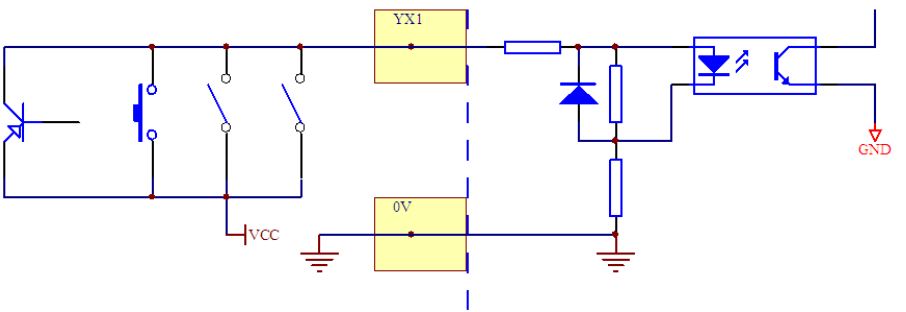

Out connect power input diagram

note: using out electric power needs more than 3V battery charge , out electric power less than 24V.

